

SERIES 375 STAIR RAILING SUPPLIMENTAL INSTRUCTION

REVISION 0.0 (4/16/2020)

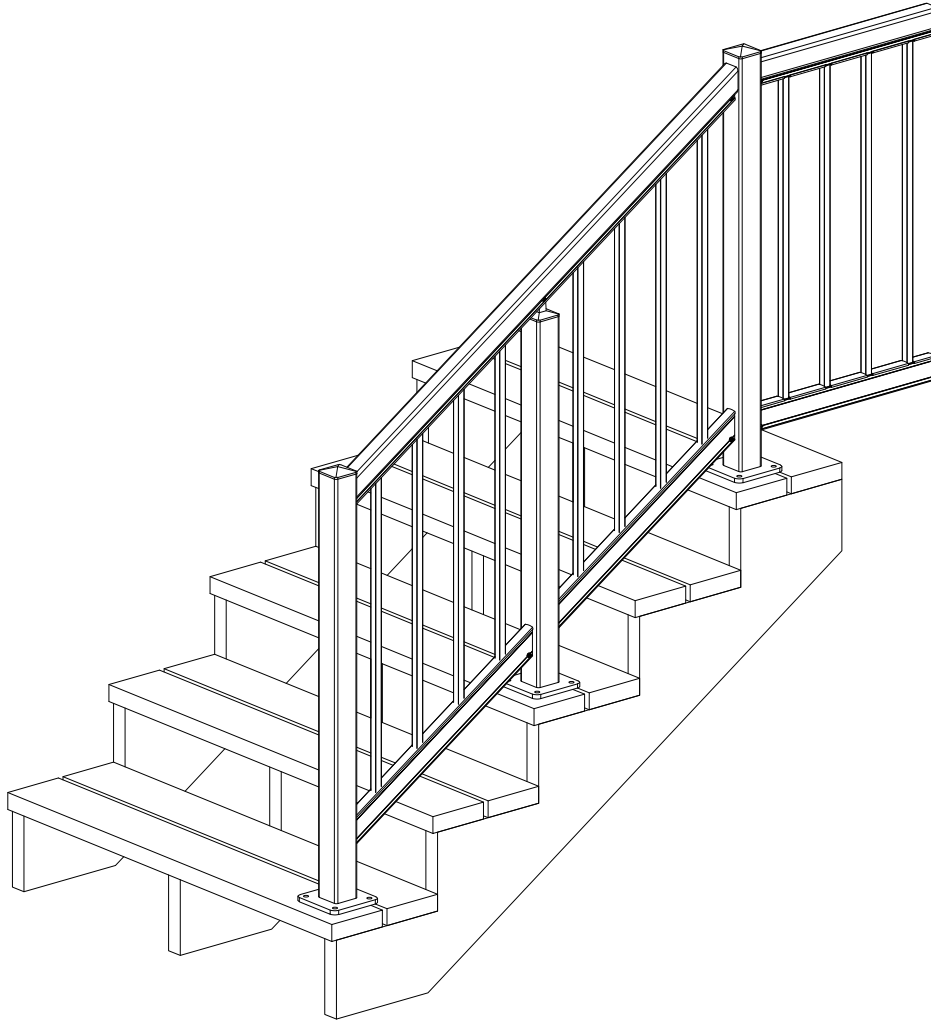

PLEASE READ THESE INSTRUCTIONS IN THEIR ENTIRETY PRIOR TO ASSEMBLING RAILING.
THESE INSTRUCTIONS ARE A SUPPLIMENT TO YOUR REGULAR RAILING INSTRUCTIONS.
IF YOU HAVE ANY QUESTIONS OR NEED ASSISTANCE, PLEASE CALL ONE OF THE NUMBERS BELOW.

DRAWING TITLE:
OVERVIEW, RAILING

DATE: 4/16/2020
DRAWN BY: TJC

PRECISION RAIL
www.precisionrail.com
503.512.5353
855.776.7245



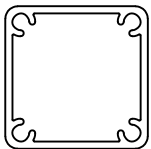

2 3/8" SQ X 45" POST

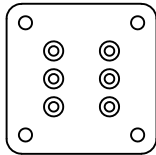

5" X 5" BASE PLATE

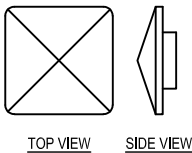

POST CAPS

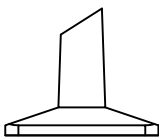

INTERMEDIATE POST FITTING

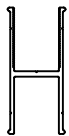

BOTTOM RAIL

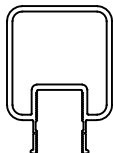

TOP RAIL



CONNECTING BLOCK (RCB-12)



PICKET



PICKET SPACER



PICKET VINYL INSERT

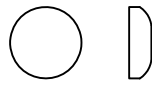

TOP VIEW SIDE VIEW

NYLON BOLT CAPS



TOP VIEW SIDE VIEW

CAP WASHERS



BASE PLATE SCREWS



#10 X 2" SS SCREWS



#10 X 5/8" SS SCREWS

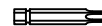

T-40 TORX IMPACT BIT

RECOMMENDED TOOLS

- SCISSORS
- CENTER PUNCH
- DRILL
- Ø11/64" DRILL BIT
- MASKING TAPE
- SOAP
- #2 PHILLIPS SCREW DRIVER BIT
- IMPACT DRIVER
- LEVEL
- PENCIL
- TAPE MEASURE
- STRING LINE
- SHIMS
- SPEED SQUARE
- ELECTRIC MITER SAW WITH A 10" CARBIDE BLADE SPECIFICALLY FOR CUTTING ALUMINUM
- RUBBER Mallet
- 4" C-CLAMP
- ANGLE FINDER

DRAWING TITLE:
OVERVIEW, PARTS LIST

DATE: 4/16/2020
DRAWN BY: TJC

PRECISION RAIL
www.precisionrail.com
503.512.5353
855.776.7245



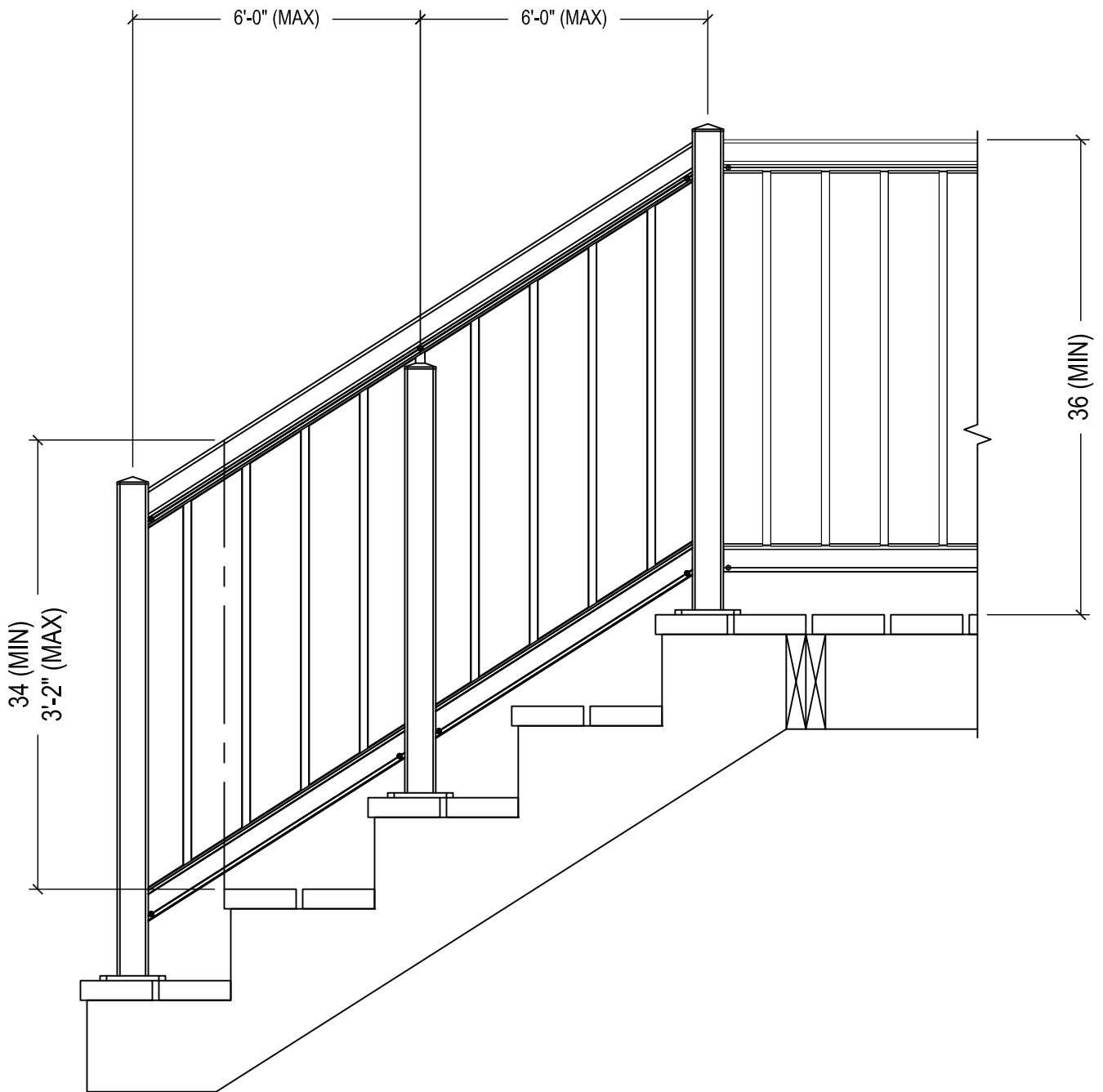

DRAWING TITLE:
OVERVIEW, DIMENSIONS

DATE: 4/16/2020
DRAWN BY: TJC

PRECISION RAIL
www.precisionrail.com
503.512.5353
855.776.7245



THINGS TO NOTE:

- STAIR RAILING IS GENERALLY INSTALLED BETWEEN 34" AND 38" HIGH (34" IS COMMON)
- A PIECE OF TOP RAIL OR BOTTOM RAIL CAN BE USED AS A STRAIGHT EDGE.
- POSTS SHOULD BE EQUAL DISTANCE FROM THE STAIR NOSE.
- ALIGN POSTS SO THAT YOUR STAIR RAIL WILL NOT BE TOO HIGH OR TOO LOW ON THE POST. SEE EXAMPLES:

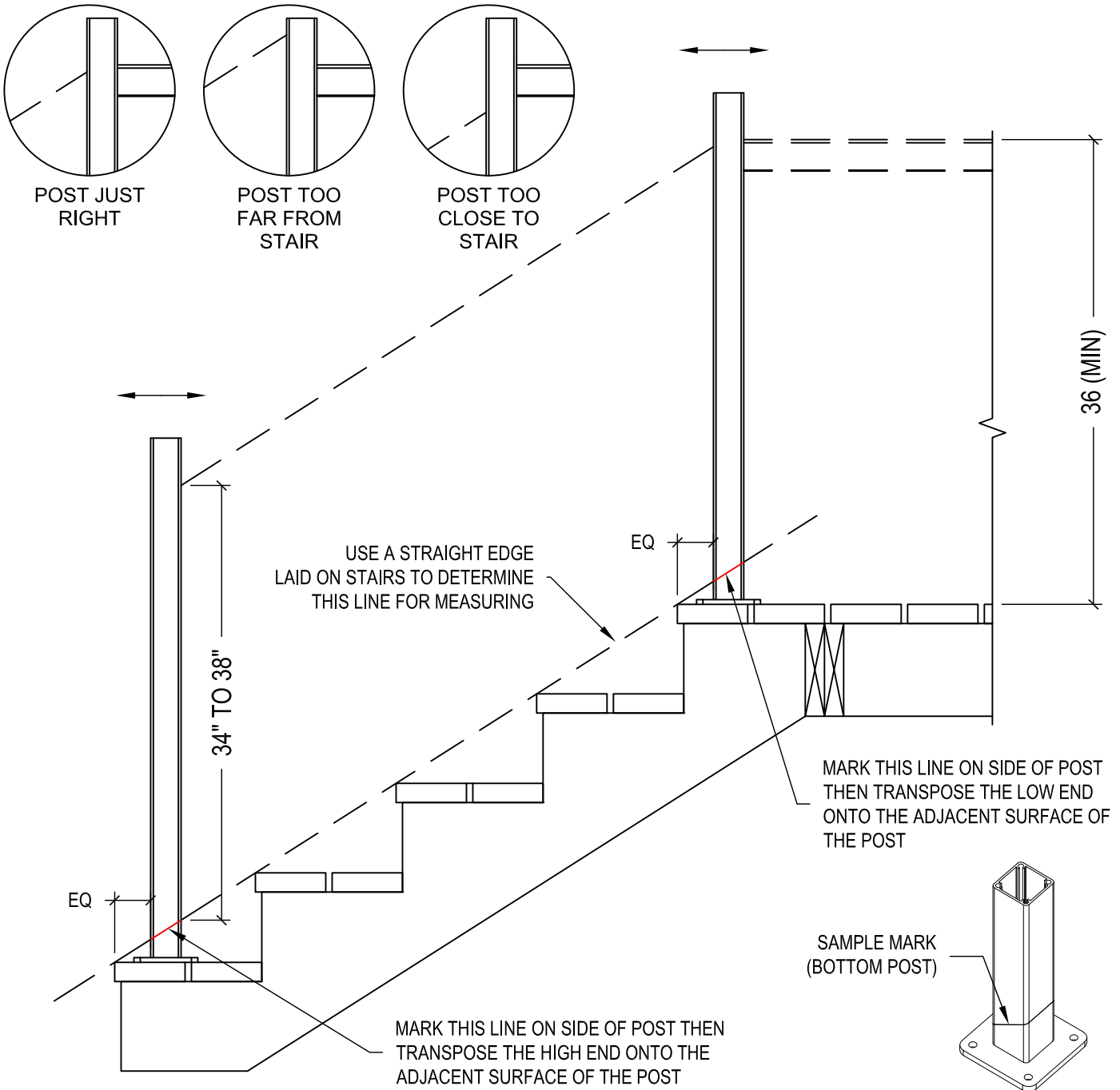

DRAWING TITLE:

PLACE AND MARK END POSTS

DATE: 4/16/2020

DRAWN BY: TJC

PRECISION RAIL
www.precisionrail.com
503.512.5353
855.776.7245



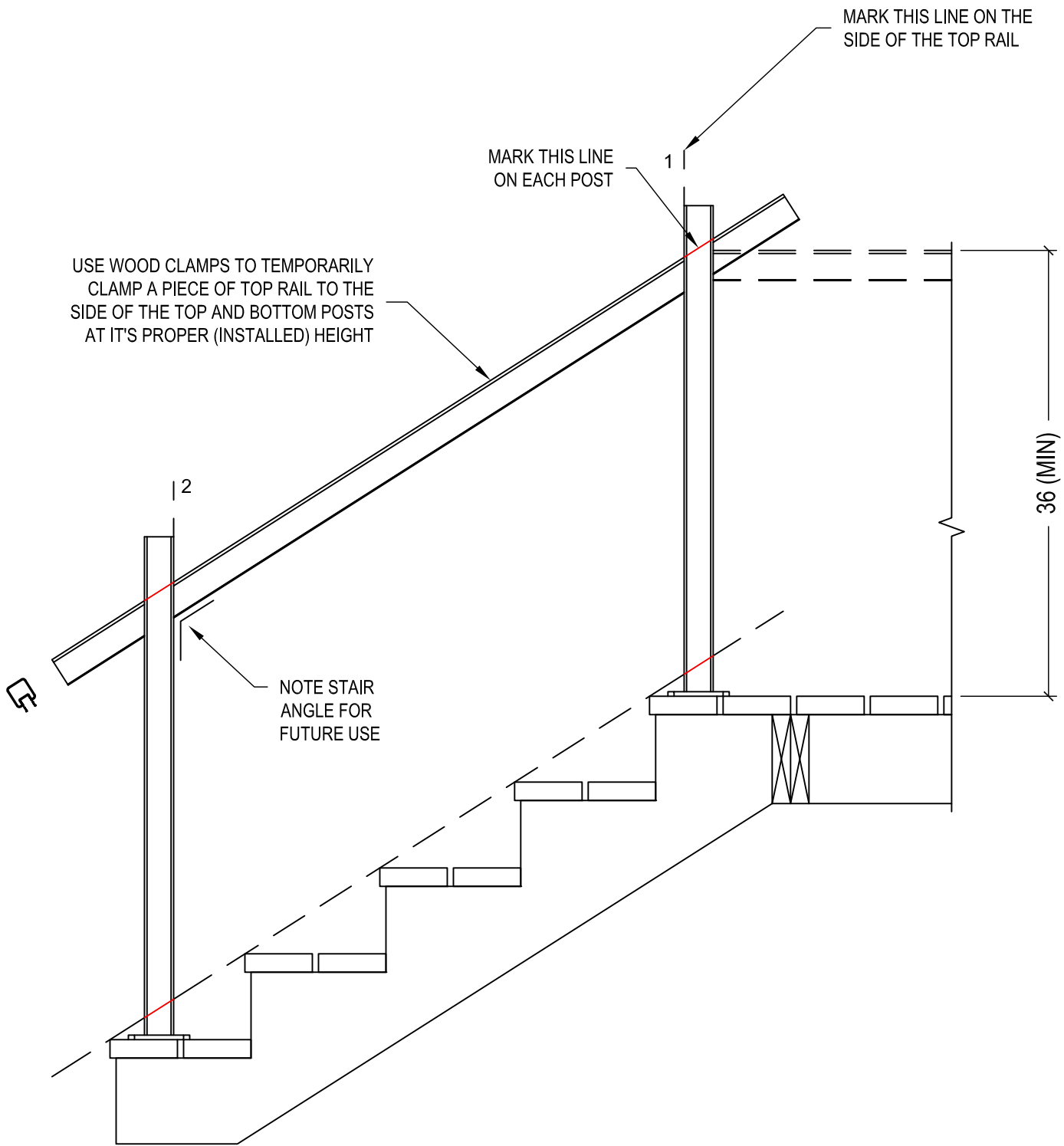

DRAWING TITLE:

PLACE AND MARK TOP RAIL

DATE: 4/16/2020

DRAWN BY: TJC

PRECISION RAIL
www.precisionrail.com
 503.512.5353
 855.776.7245



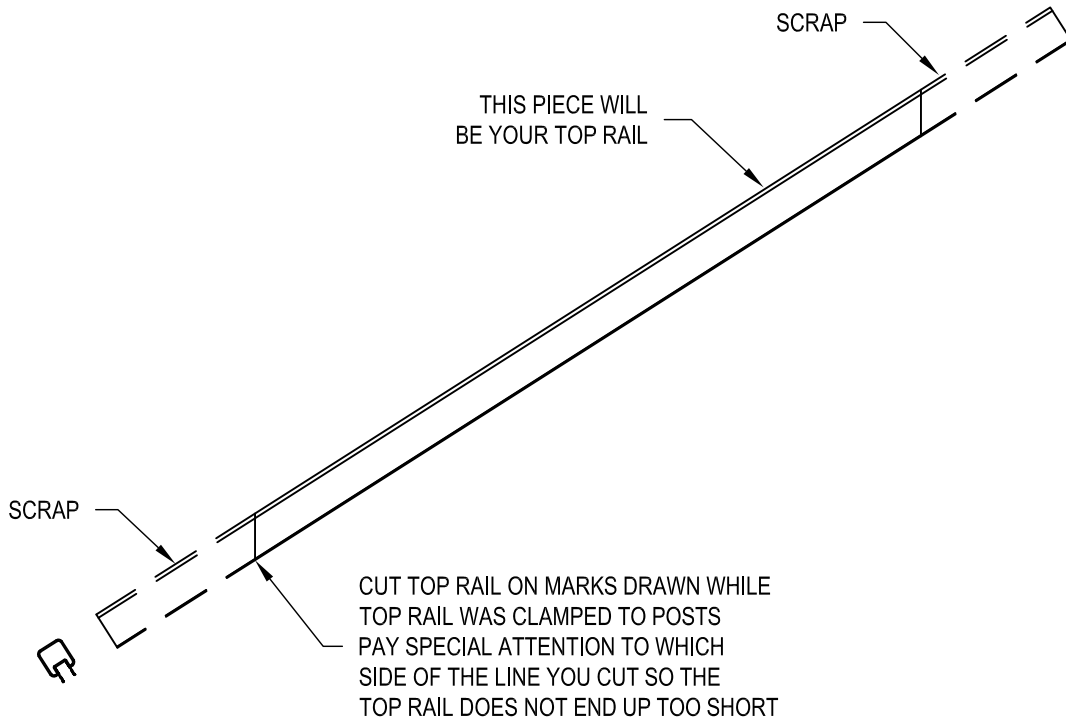

CUT TOP RAIL

MARK THE RCB WITH LINES AT THE SAME ANGLE AS YOUR STAIR, NOTE, EVERY OTHER LINE IS PERPENDICULAR, NOT ANGLED.

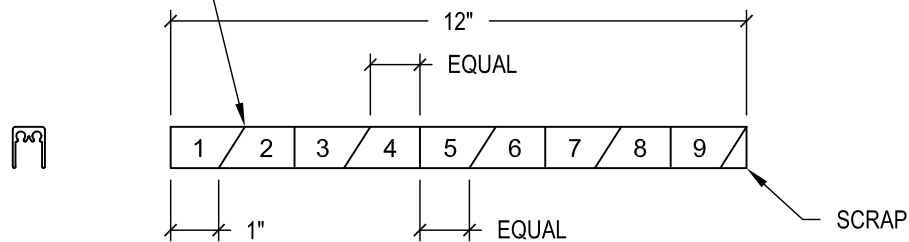

CUT RAIL CONN. BLK (RCB)

DRAWING TITLE:

CUT TOP RAIL AND RCB

DATE: 4/16/2020

DRAWN BY: TJC

PRECISION RAIL
www.precisionrail.com
503.512.5353
855.776.7245



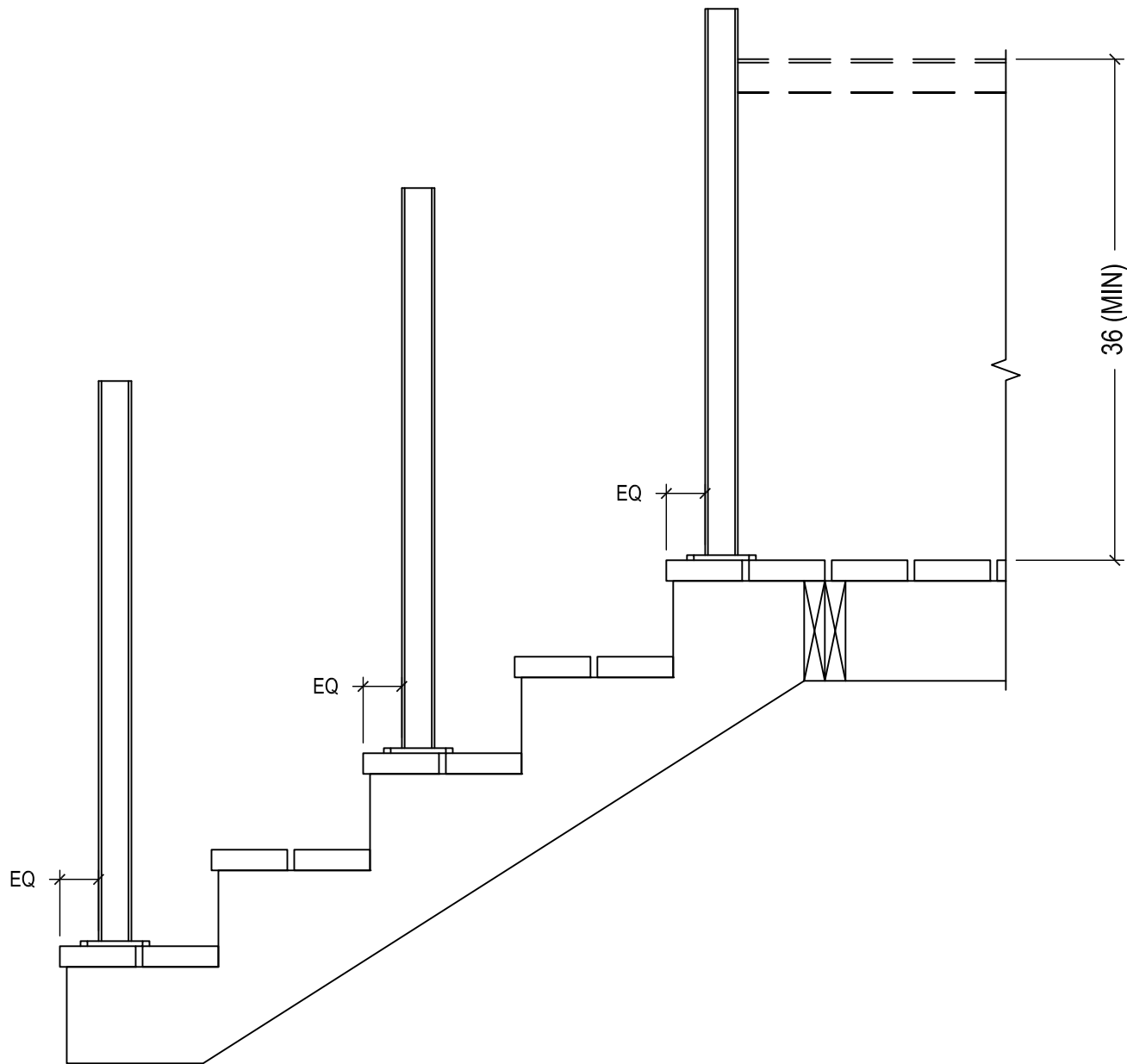

DRAWING TITLE:

PLACE MID POST(S) IF REQ'D

DATE: 4/16/2020

DRAWN BY: TJC

PRECISION RAIL
www.precisionrail.com
503.512.5353
855.776.7245



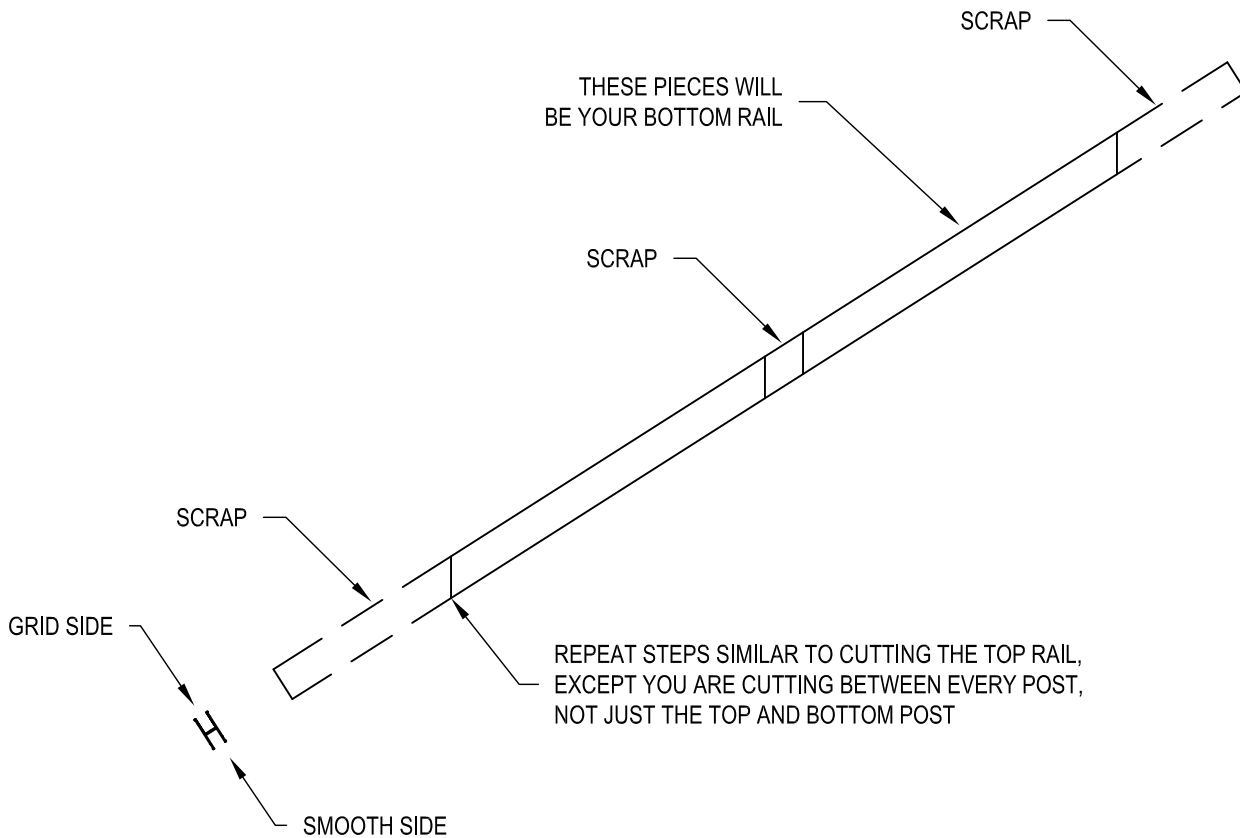

CUT BOTTOM RAIL

DRAWING TITLE:

CUT BOTTOM RAIL

DATE: 4/16/2020

DRAWN BY: TJC

PRECISION RAIL
www.precisionrail.com
 503.512.5353
 855.776.7245



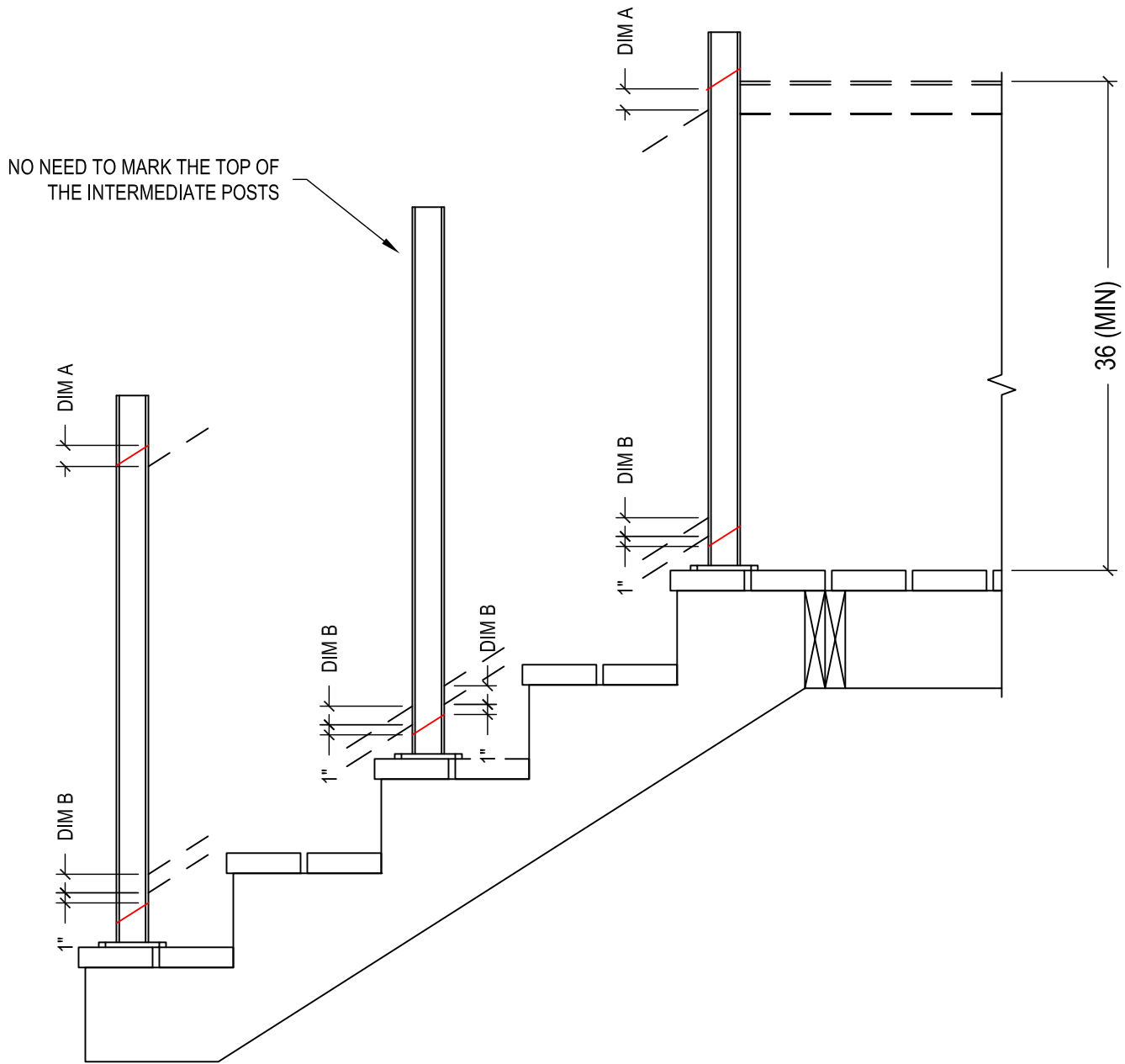

DRAWING TITLE:

MARK POST FOR RCB INSTALLATION

DATE: 4/16/2020

DRAWN BY: TJC

PRECISION RAIL
www.precisionrail.com
 503.512.5353
 855.776.7245



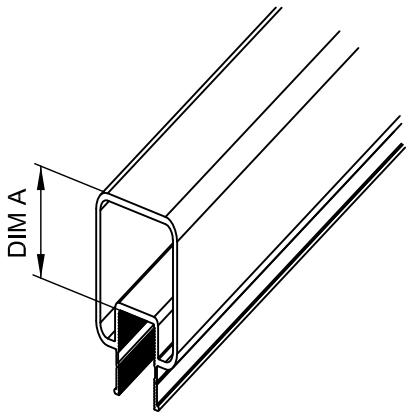

MARK TOP OF TOP RAIL
MARK DIM A
TOP RAIL RCB

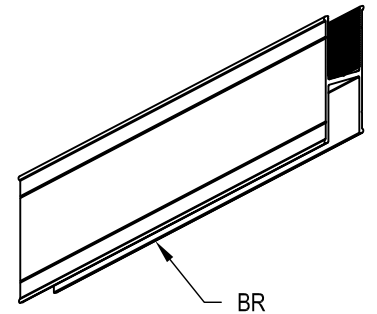
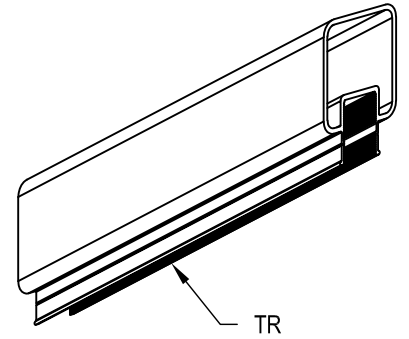

BOTTOM RAIL RCB
MARK DIM B
MARK BOTTOM OF BOTTOM RAIL
LINE AT STAIR NOSE

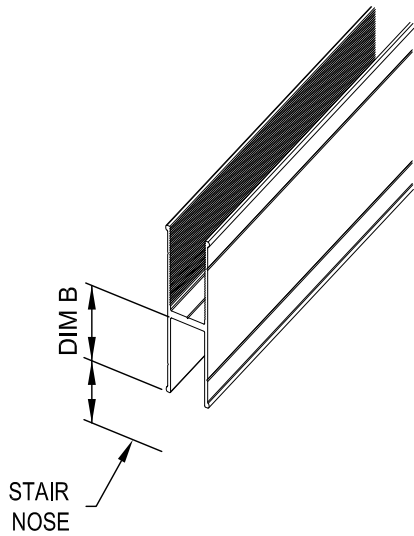

DRAWING TITLE:
MARK POST FOR RCB INSTALLATION

DATE: 4/16/2020
DRAWN BY: TJC

PRECISION RAIL
www.precisionrail.com
503.512.5353
855.776.7245



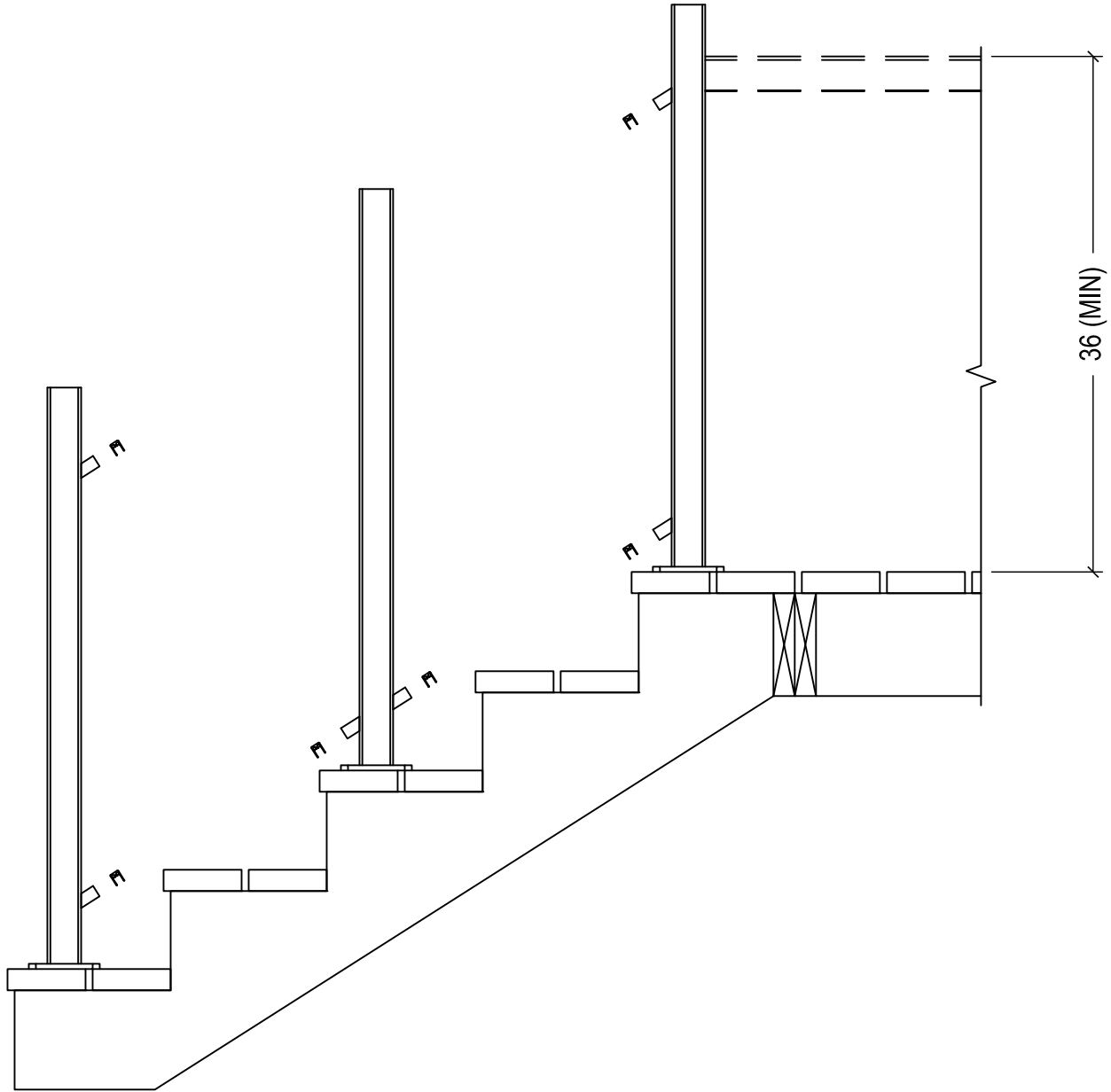

DRAWING TITLE:
RCB PLACEMENT

DATE: 4/16/2020
DRAWN BY: TJC

PRECISION RAIL
www.precisionrail.com
503.512.5353
855.776.7245



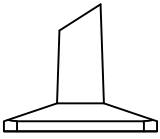

INTERMEDIATE
POST FITTING
(IPF)

TEMPORARILY PLACE YOUR TOP
RAIL TO MARK THE MIDDLE
POSTS WHERE YOU NEED TO
CUT THEM SO THE IPF CAN BE
INSTALLED PROPERLY BEFORE
THE TOP RAIL IS ATTACHED.

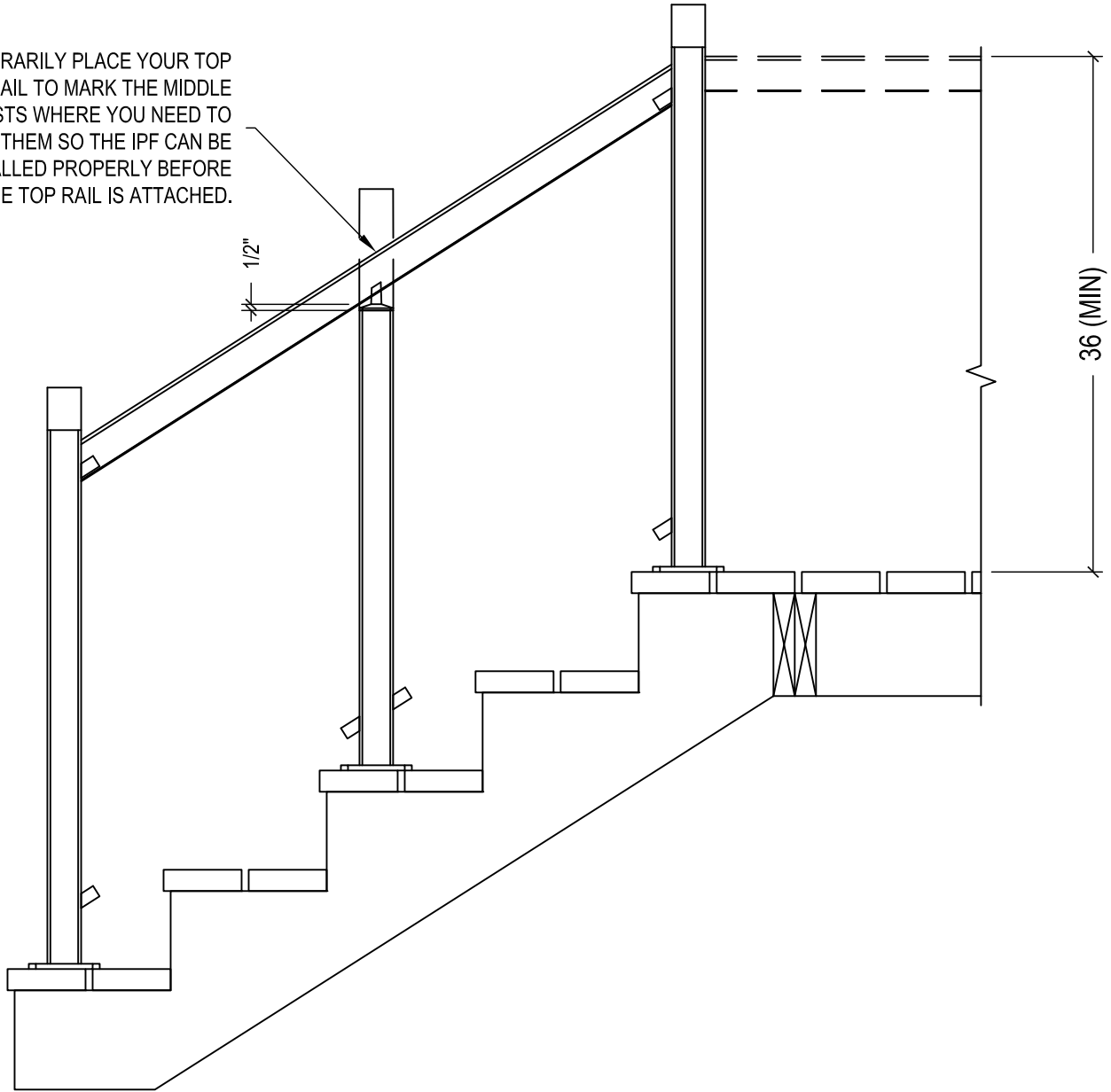

DRAWING TITLE:

CUT POST(S) TO HEIGHT

DATE: 4/16/2020

DRAWN BY: TJC

PRECISION RAIL
www.precisionrail.com
503.512.5353
855.776.7245



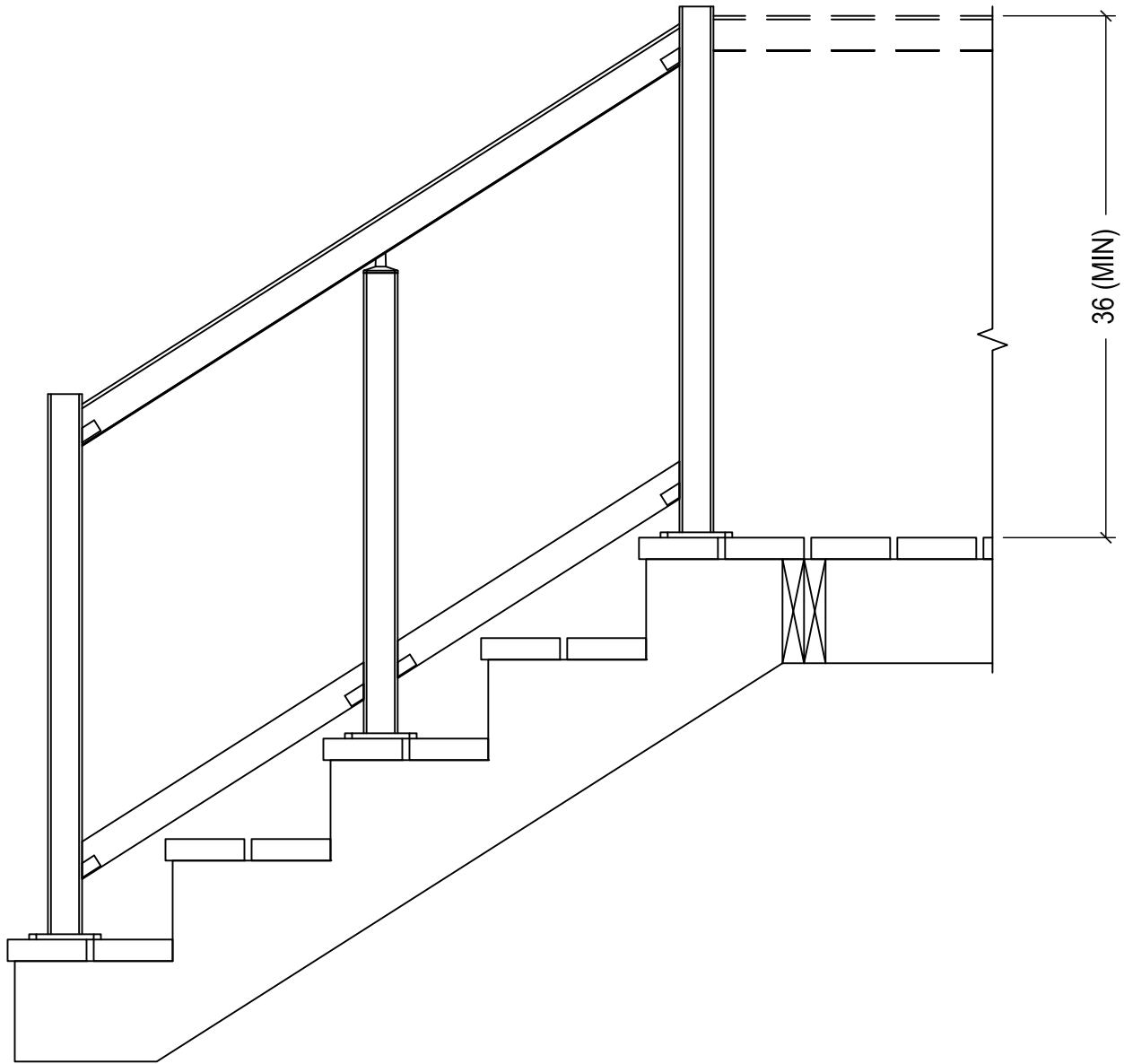

DRAWING TITLE:

INSTALL BOTTOM RAIL

DATE: 4/16/2020

DRAWN BY: TJC

PRECISION RAIL
www.precisionrail.com
503.512.5353
855.776.7245



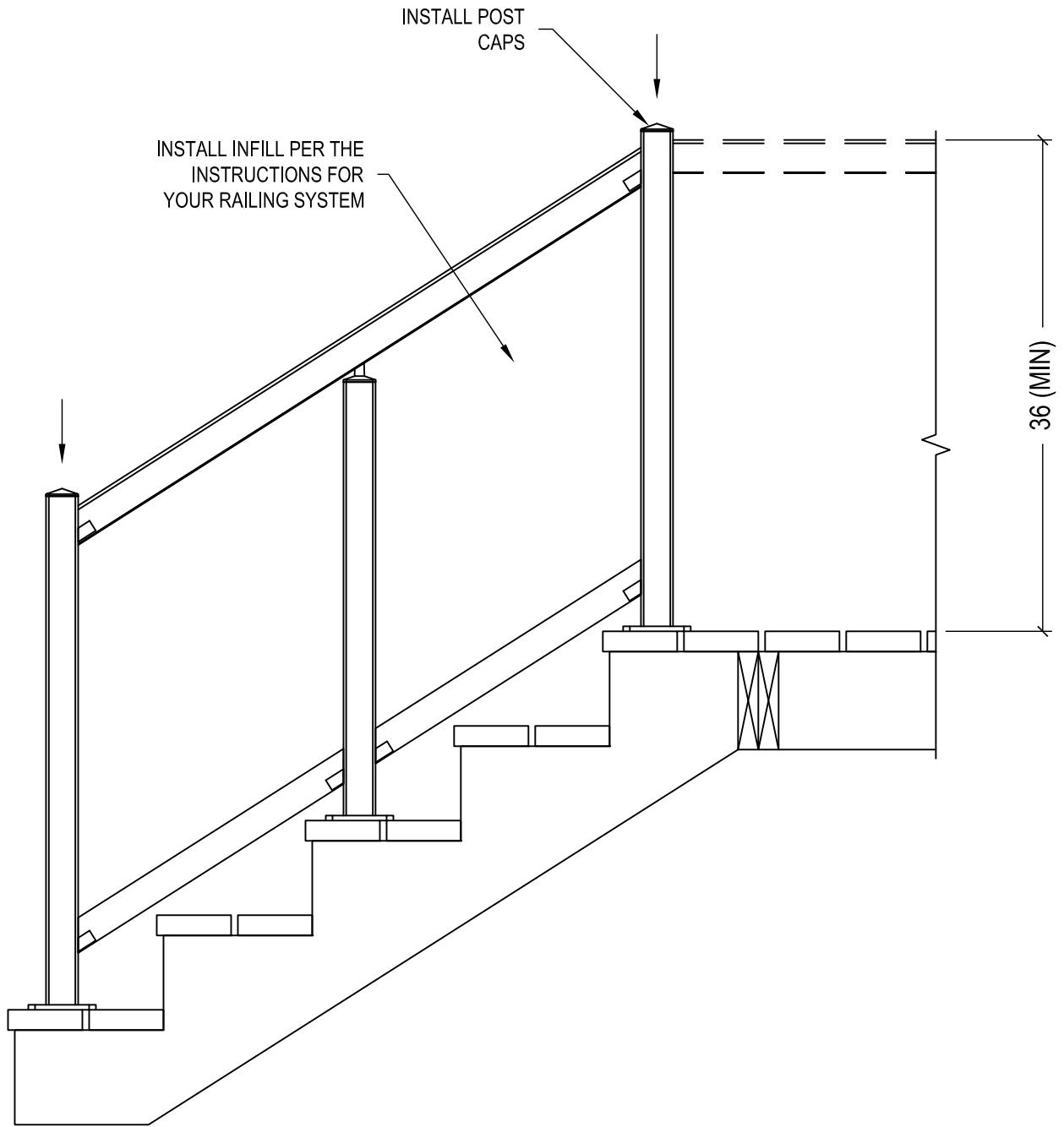

DRAWING TITLE:
FINAL STEPS

DATE: 4/16/2020
DRAWN BY: TJC

PRECISION RAIL
www.precisionrail.com
503.512.5353
855.776.7245

