

SERIES 400 CABLE RAILING INSTALLATION INSTRUCTIONS

REVISION 0.0 (4/16/2020)

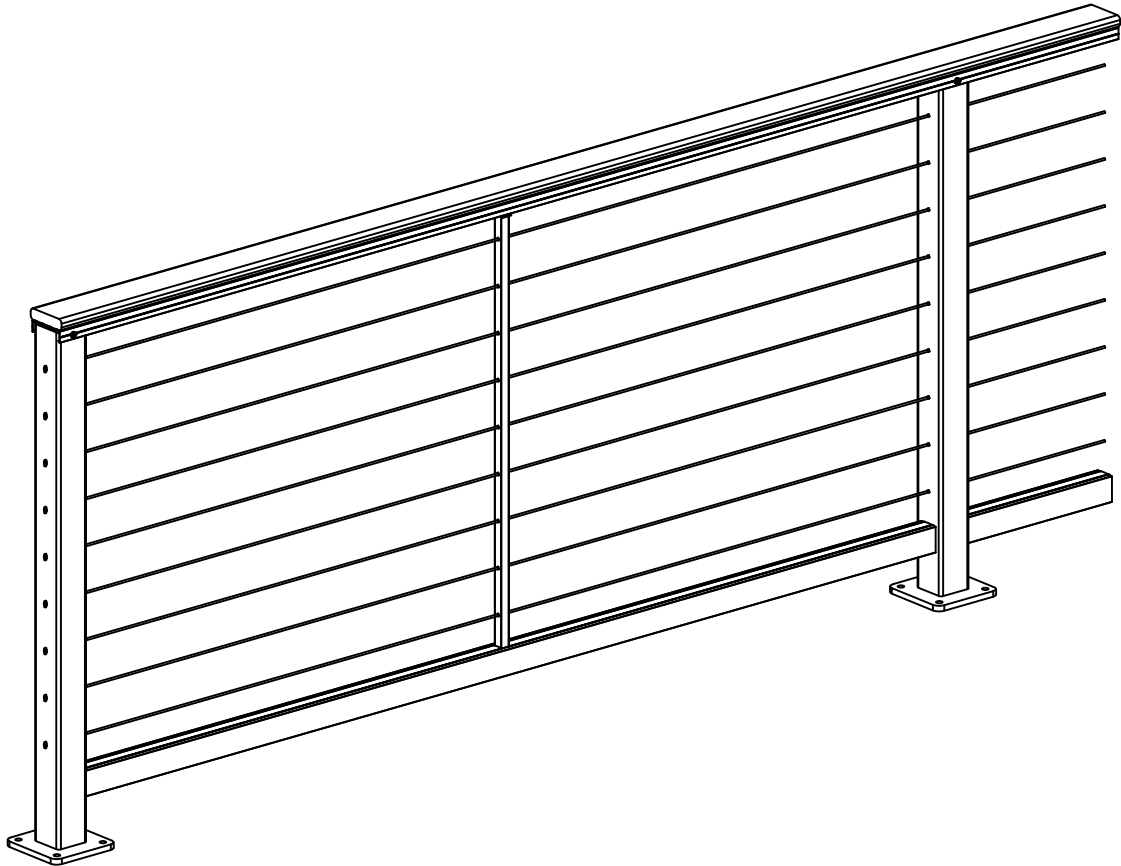

PLEASE READ THESE INSTRUCTIONS IN THEIR ENTIRETY PRIOR TO ASSEMBLING RAILING.
IF YOU HAVE ANY QUESTIONS OR NEED ASSISTANCE, PLEASE CALL ONE OF THE NUMBERS BELOW.

DRAWING TITLE:
OVERVIEW, RAILING

DATE: 4/16/2020
DRAWN BY: TJC

PRECISION RAIL
www.precisionrail.com
503.512.5353
855.776.7245



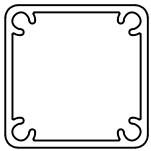

2 3/8" SQ POST

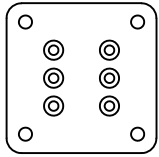

5" X 5" BASE PLATE

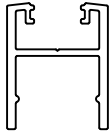

BOTTOM RAIL

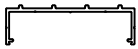

TOP RAIL



TOP RAIL INFILL

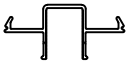

TOP RAIL PICKET INFILL



PICKET



CONNECTING BLOCK



BOTTOM RAIL CAP

STOCK LENGTH MATERIAL



TOP VIEW



SIDE VIEW

NYLON BOLT CAPS



TOP VIEW



SIDE VIEW

CAP WASHERS



BASE PLATE SCREWS



#10 X 2" SS SCREWS

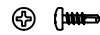

#10 X 5/8" SS SCREWS



#8 X 3/4" FH SS SCREWS

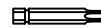

(1) T-40 TORX IMPACT BIT

HARDWARE

RECOMMENDED TOOLS

- SCISSORS
- CENTER PUNCH
- DRILL
- Ø11/64" AND Ø5/16" DRILL BITS
- MASKING TAPE
- SOAP
- #2 PHILLIPS SCREW DRIVER BIT
- IMPACT DRIVER
- LEVEL
- PENCIL
- TAPE MEASURE
- STRING LINE
- SHIMS
- SPEED SQUARE
- ELECTRIC MITER SAW WITH A 10" CARBIDE BLADE SPECIFICALLY FOR CUTTING ALUMINUM
- RUBBER Mallet
- 4" C-CLAMP
- CABLE CUTTER
- CABLE SWAGE TOOL

DRAWING TITLE:
OVERVIEW, PARTS LIST

DATE: 4/16/2020
DRAWN BY: TJC

PRECISION RAIL
www.precisionrail.com
503.512.5353
855.776.7245



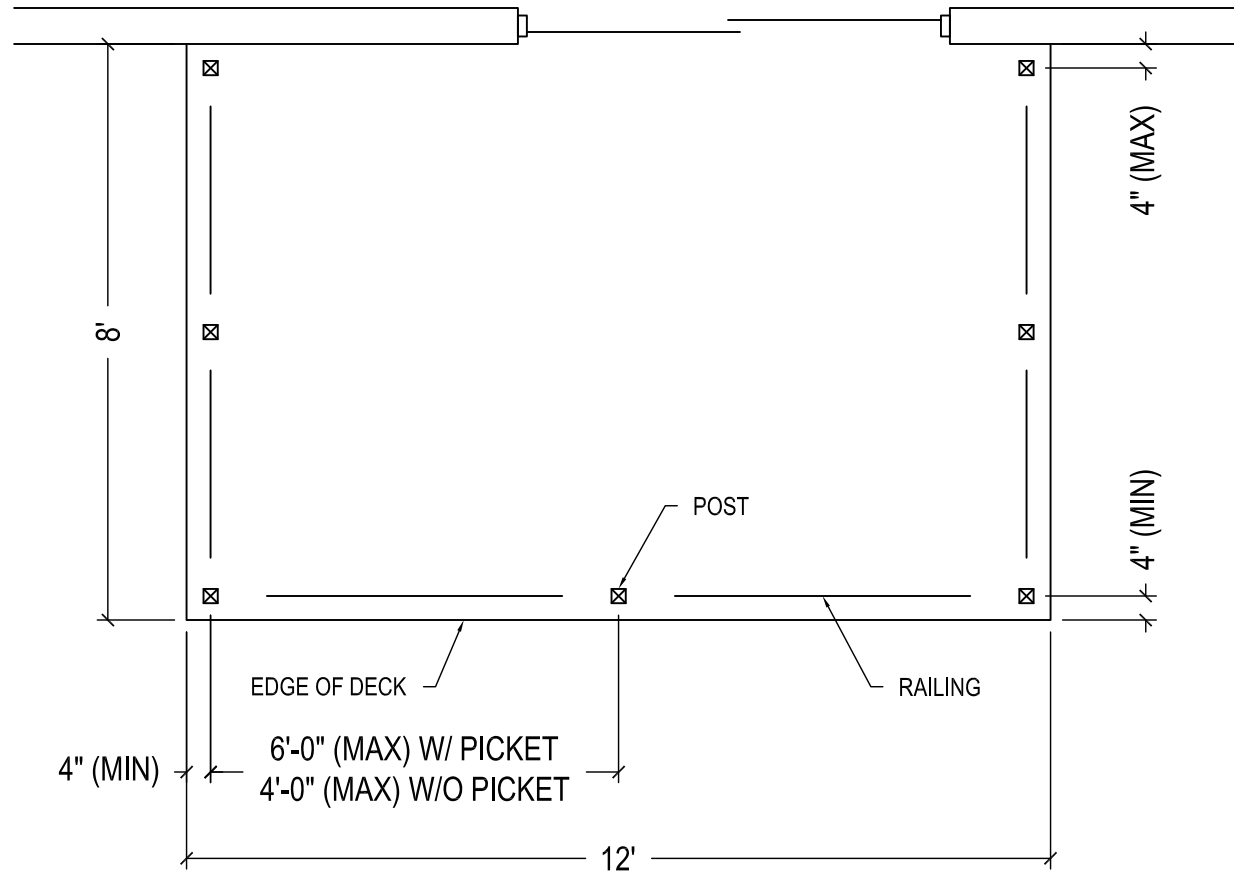

SAMPLE DECK PLAN

NOT TO SCALE

THINGS TO NOTE:

- WHICH SIDES OF YOUR POSTS GET DRILLED FOR RAILING CONNECTION BLOCKS.
- MAXIMUM POST SPACING IS 6'-0" FROM CENTER OF POST TO CENTER OF POST WITH A MID-SPAN PICKET.
- MAXIMUM POST SPACING IS 4'-0" FROM CENTER OF POST TO CENTER OF POST WITHOUT A MID-SPAN PICKET.
- ALL GAPS, INCLUDING THE SPACE BETWEEN A WALL AND A POST CANNOT EXCEED 4".
- THE CENTERLINE OF YOUR RAILING SHOULD BE A MINIMUM OF 4" FROM THE EDGE OF DECK.
- IT IS RECOMMENDED THAT YOU SHOULD SPACE YOUR POSTS AN EQUAL DISTANCE APART WHEREVER POSSIBLE.

DRAWING TITLE:

OVERVIEW, SAMPLE DECK PLAN

DATE: 4/16/2020

DRAWN BY: TJC

PRECISION RAIL
www.precisionrail.com
 503.512.5353
 855.776.7245



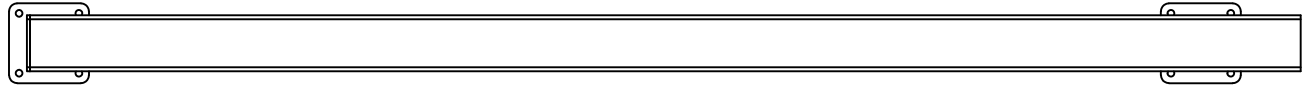

6'-0" MAX POST SPACING (CENTER TO CENTER) WITH PICKET
4'-0" MAX POST SPACING (CENTER TO CENTER) WITHOUT PICKET

EQ

EQ

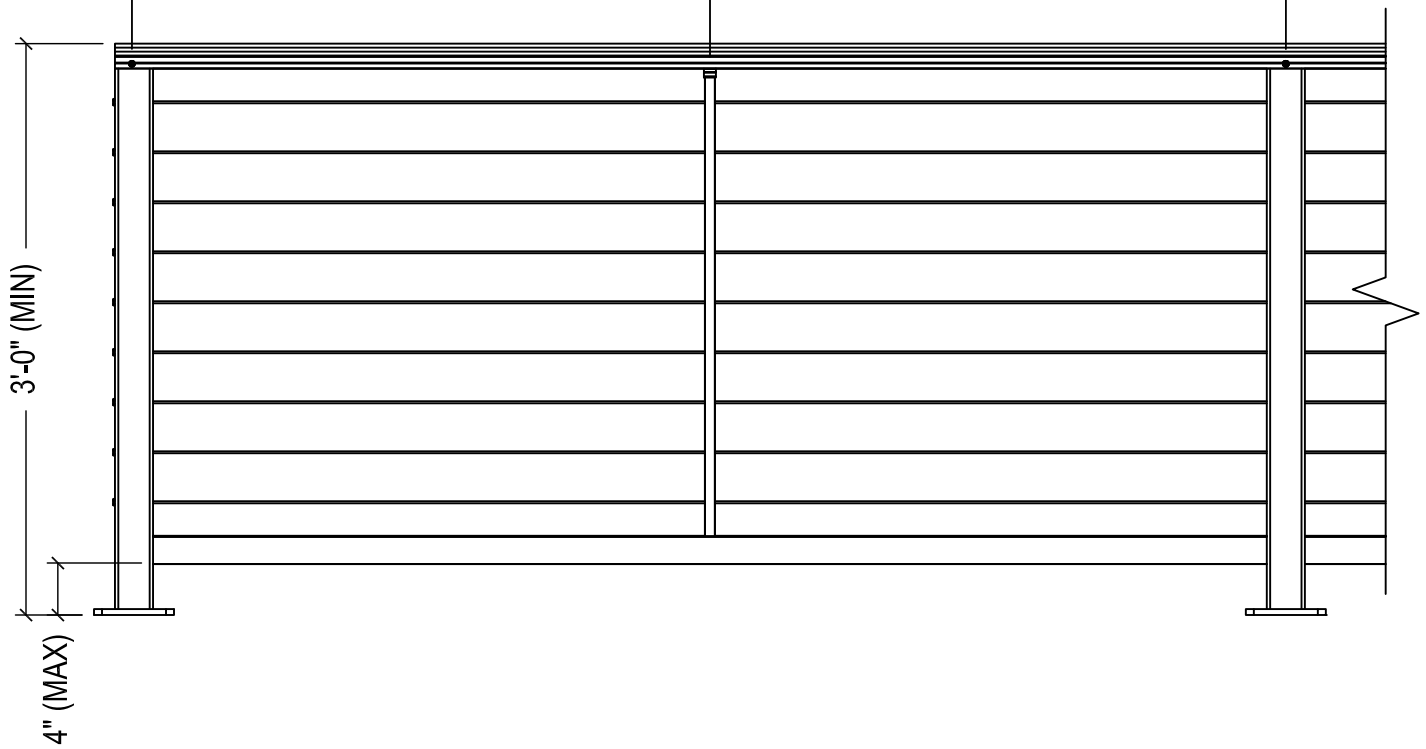

DRAWING TITLE:
OVERVIEW, DIMENSIONS

DATE: 4/16/2020
DRAWN BY: TJC

PRECISION RAIL
www.precisionrail.com
503.512.5353
855.776.7245



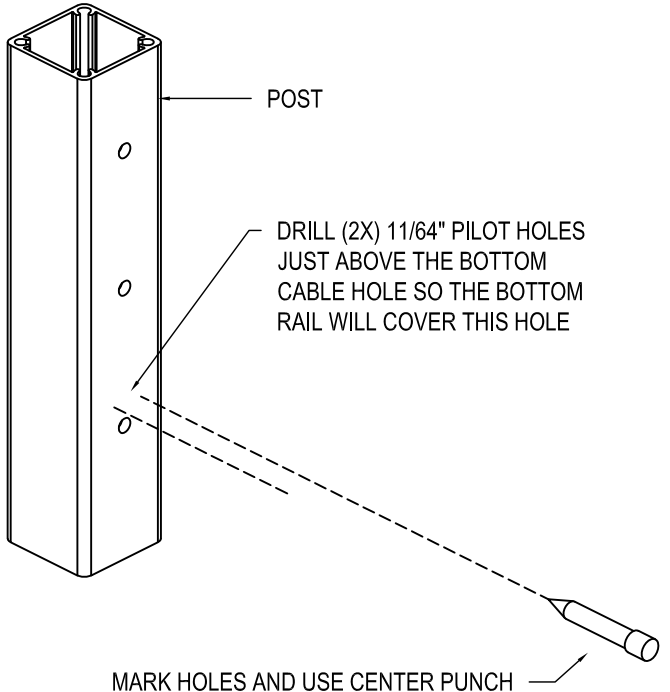

CENTER PUNCH AND DRILL BOTTOM HOLES

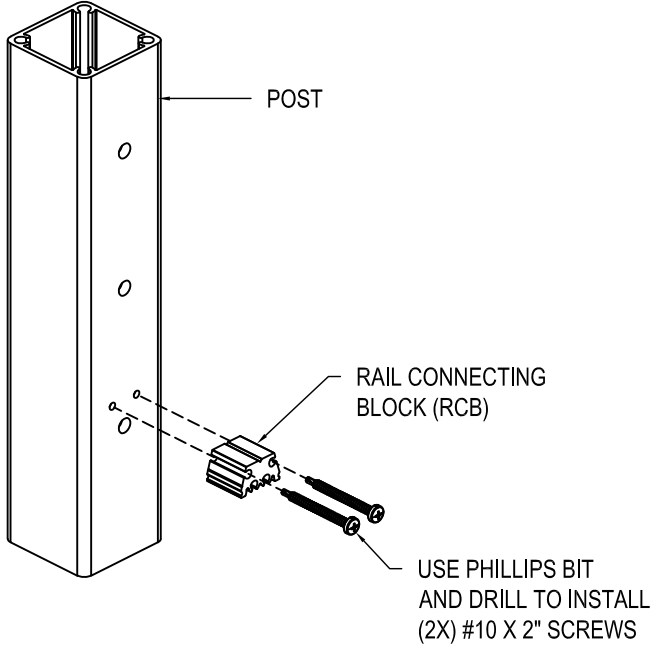

INSTALL BOTTOM CONNECTING BLOCK

DRAWING TITLE:
STEP 1: RCB INSTALLATION

DATE: 4/16/2020
DRAWN BY: TJC

PRECISION RAIL
www.precisionrail.com
503.512.5353
855.776.7245



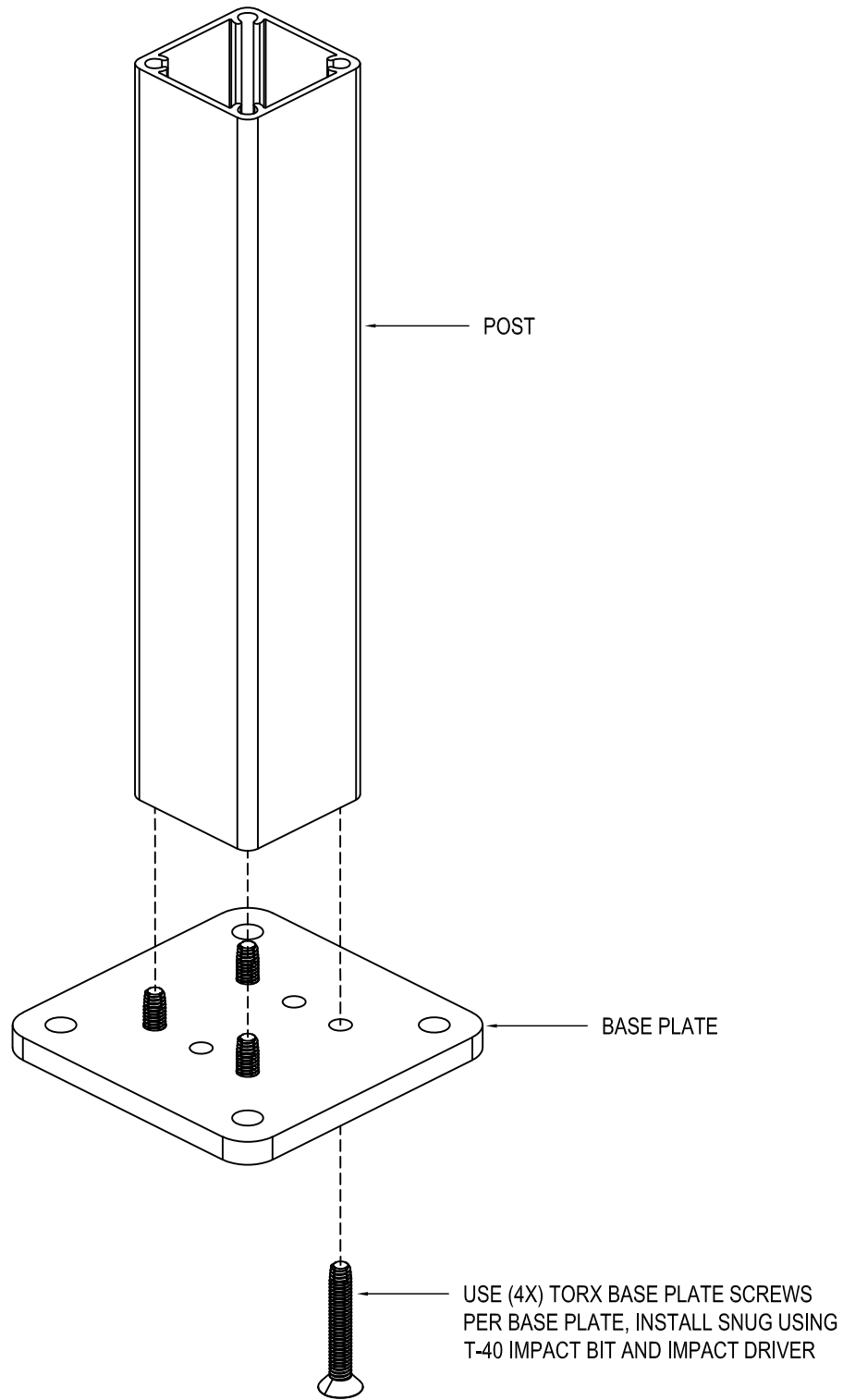

DRAWING TITLE:

STEP 2: BASE PLATE INSTALLATION

DATE: 4/16/2020

DRAWN BY: TJC

PRECISION RAIL
www.precisionrail.com
503.512.5353
855.776.7245



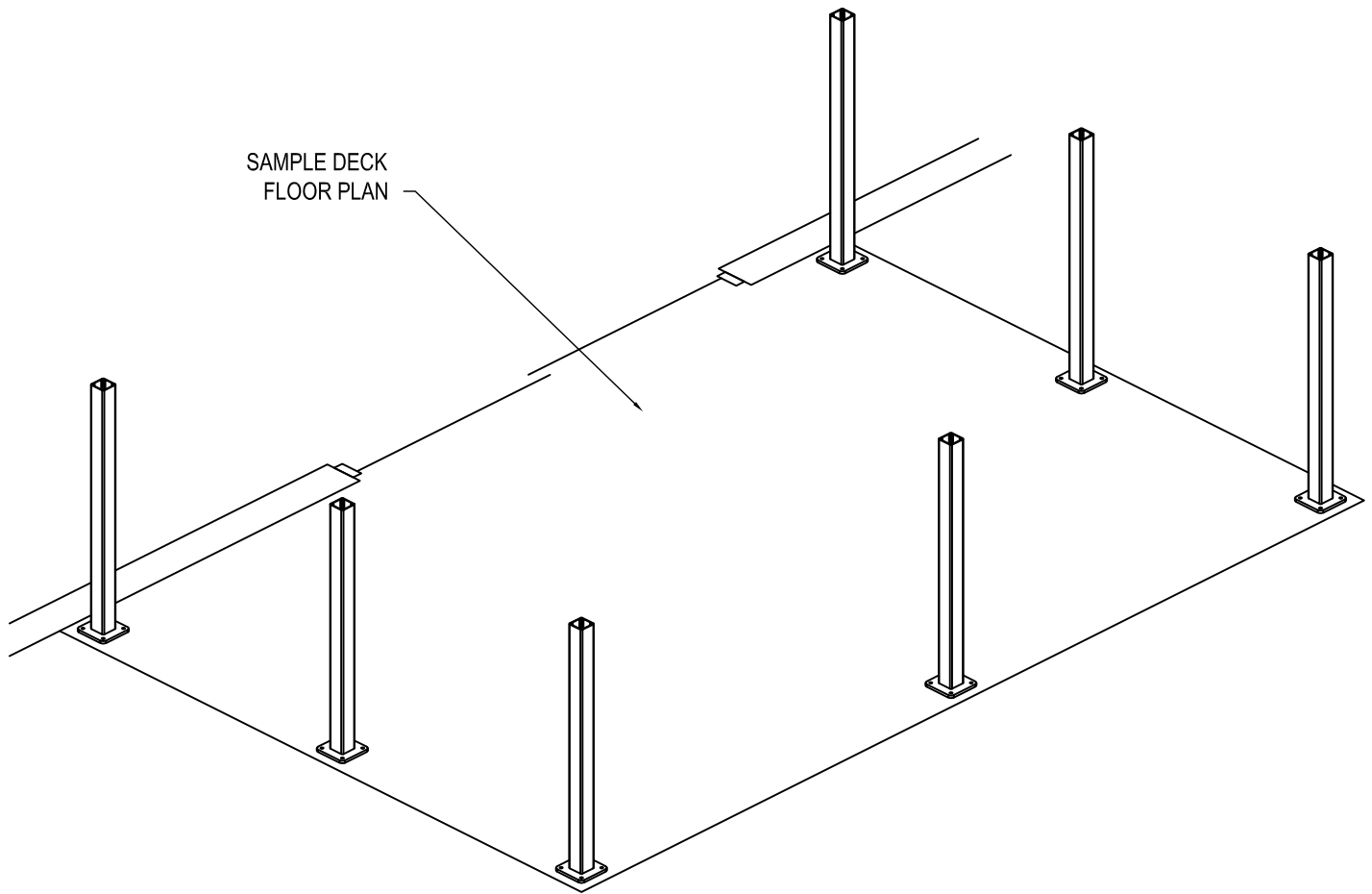

THINGS TO NOTE:

- USING A TAPE MEASURE AND A STRING LINE, PLACE ALL OF YOUR POSTS IN THEIR PROPER LOCATIONS PER YOUR DECK PLANS. ENSURE THAT YOUR CABLES HOLES ARE ALL IN THE PROPER ORIENTATION.
- USE A LEVEL ON TWO ADJACENT SIDES OF EACH POST TO ENSURE THE POST IS PLUMB. IF IT IS NOT, USE SHIMS AS REQUIRED UNDER THE BASE PLATE.
- BE SURE TO FOLLOW MINIMUM AND MAXIMUM DIMENSIONAL REQUIREMENTS AS LISTED ON THE SAMPLE DECK PLAN.

DRAWING TITLE:

STEP 3: PLACING THE POSTS

DATE: 4/16/2020

DRAWN BY: TJC

PRECISION RAIL
www.precisionrail.com
503.512.5353
855.776.7245



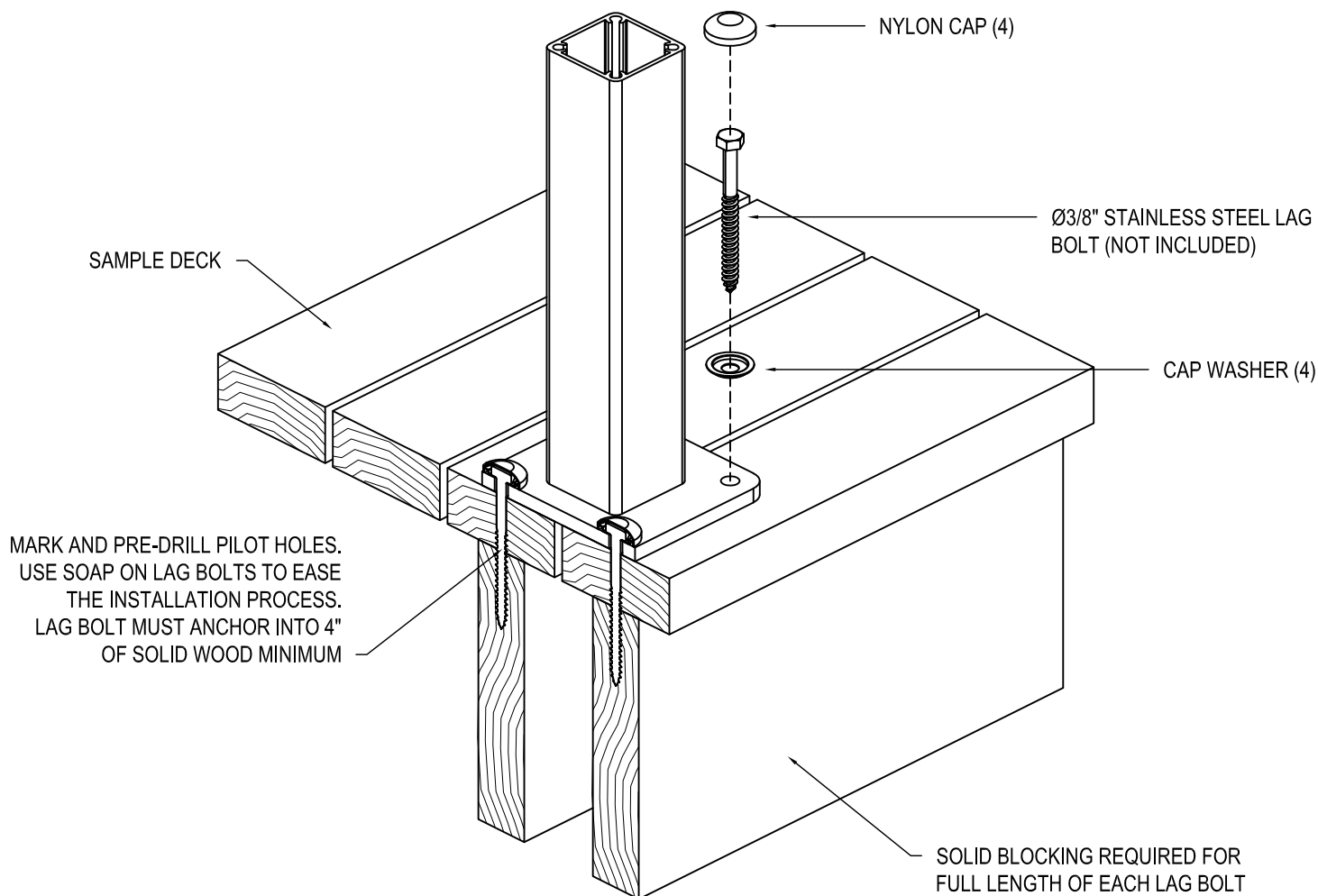

SAMPLE ONLY

LAG BOLTS NOT INCLUDED

DRAWING TITLE:

STEP 3: TYP WOOD CONNECTION

DATE: 4/16/2020

DRAWN BY: TJC

PRECISION RAIL
www.precisionrail.com
 503.512.5353
 855.776.7245



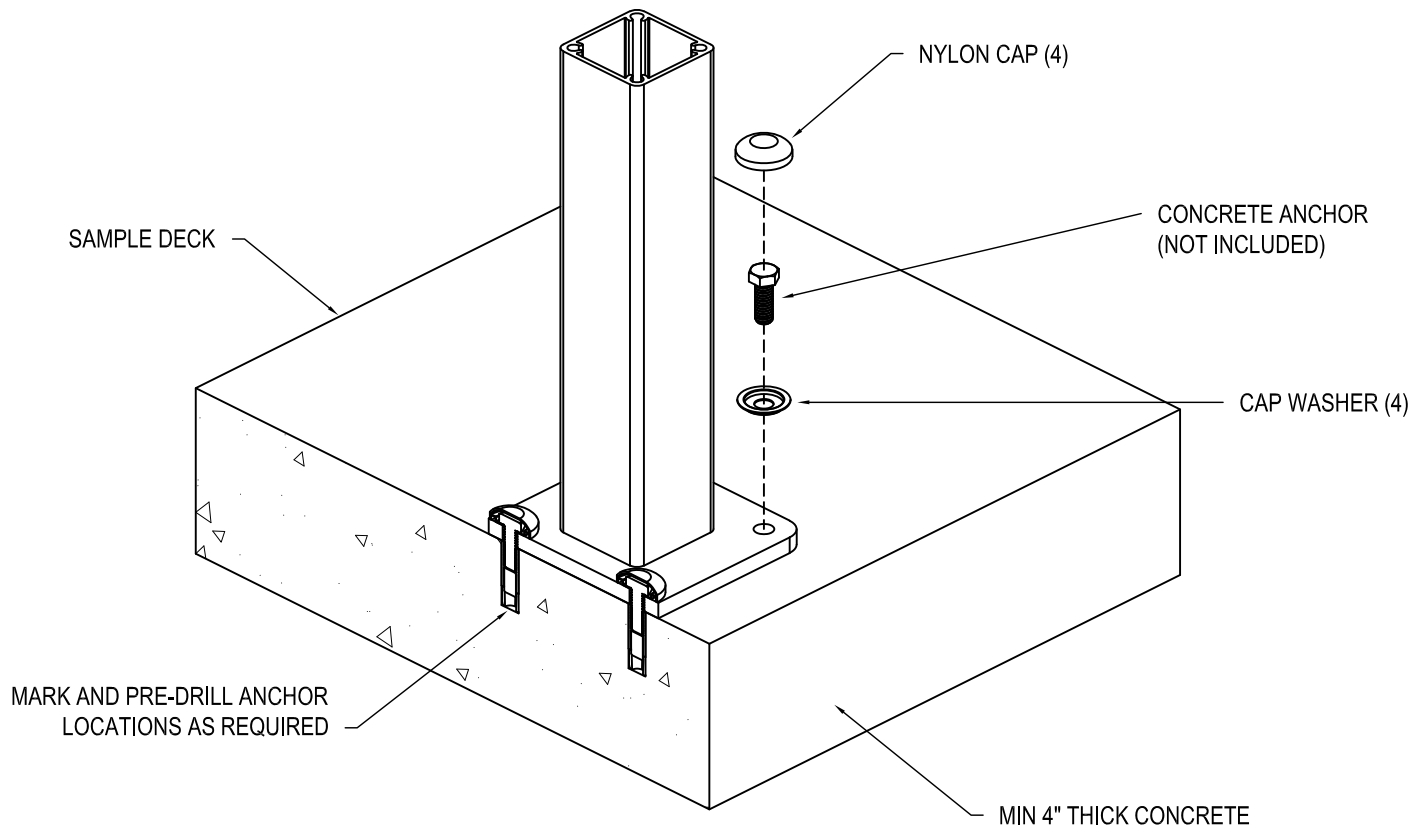

SAMPLE ONLY

ANCHOR BOLTS NOT INCLUDED

DRAWING TITLE:

STEP 3: TYP CONCRETE CONNECTION

DATE: 4/16/2020

DRAWN BY: TJC

PRECISION RAIL
www.precisionrail.com
 503.512.5353
 855.776.7245



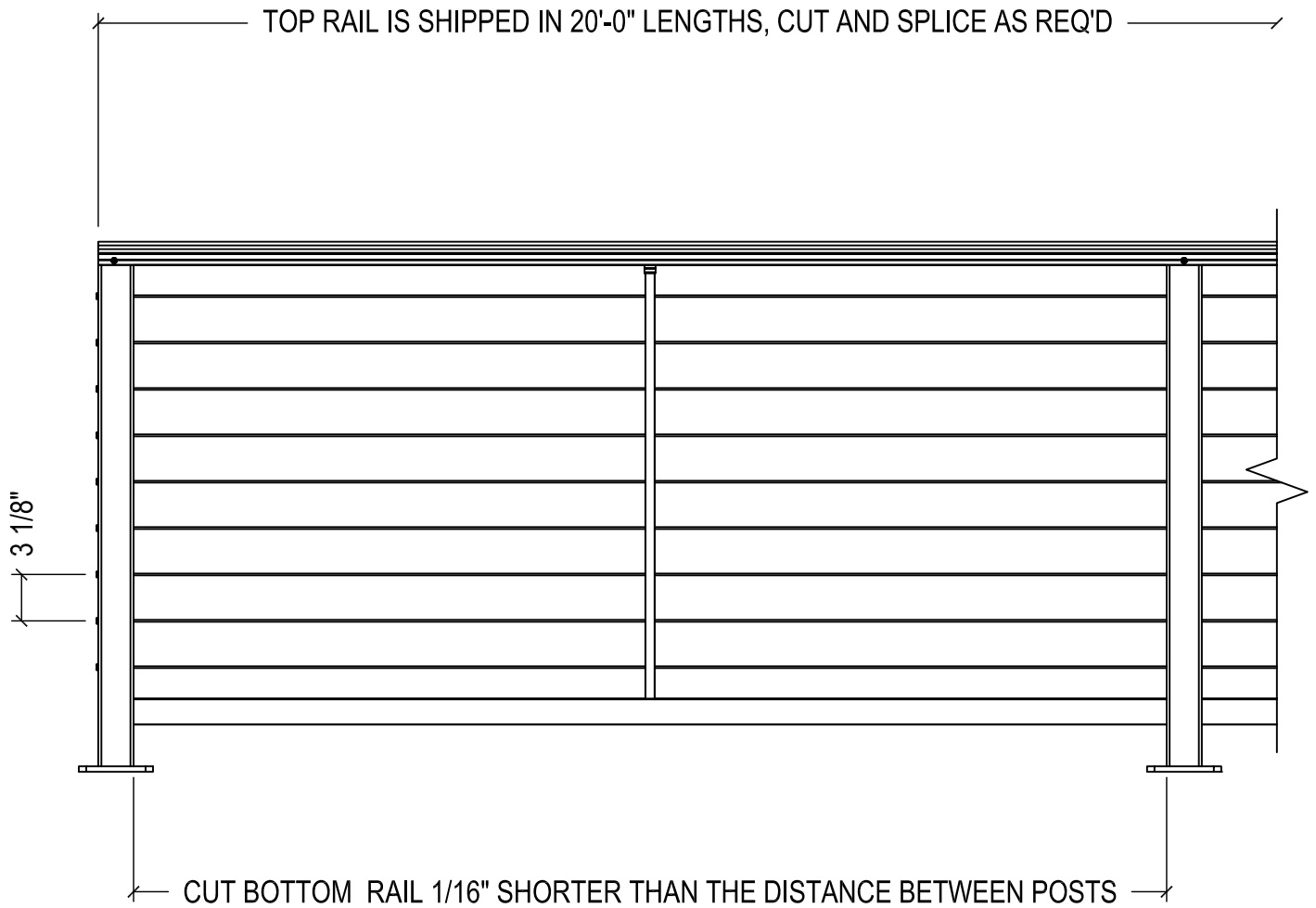

THINGS TO NOTE:

- INSTALL ALL POSTS BEFORE CUTTING TOP AND BOTTOM RAILS.
- USE AN ELECTRIC MITER SAW WITH A 10" CARBIDE BLADE SPECIFICALLY FOR CUTTING ALUMINUM.
- CUT AND DOUBLE CHECK FIT BEFORE ATTACHING RAILS WITH SCREWS

DRAWING TITLE:

STEP 4: TOP AND BOTTOM RAIL

DATE: 4/16/2020

DRAWN BY: TJC

PRECISION RAIL
www.precisionrail.com
 503.512.5353
 855.776.7245



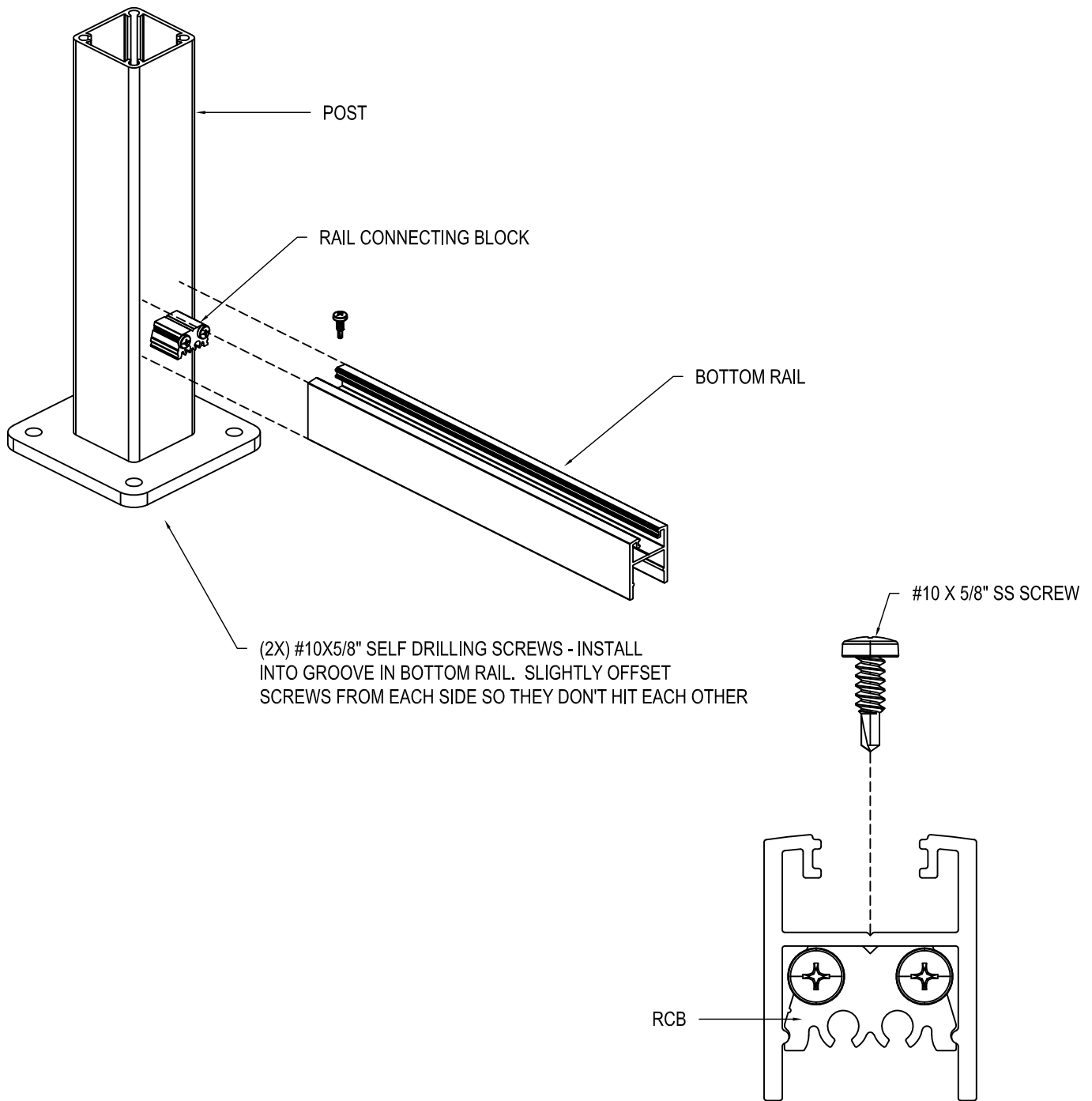

INSTALL BOTTOM RAIL BEFORE TOP RAIL

DRAWING TITLE:

STEP 4: BOTTOM RAIL INSTALLATION

DATE: 4/16/2020

DRAWN BY: TJC

PRECISION RAIL
www.precisionrail.com
 503.512.5353
 855.776.7245



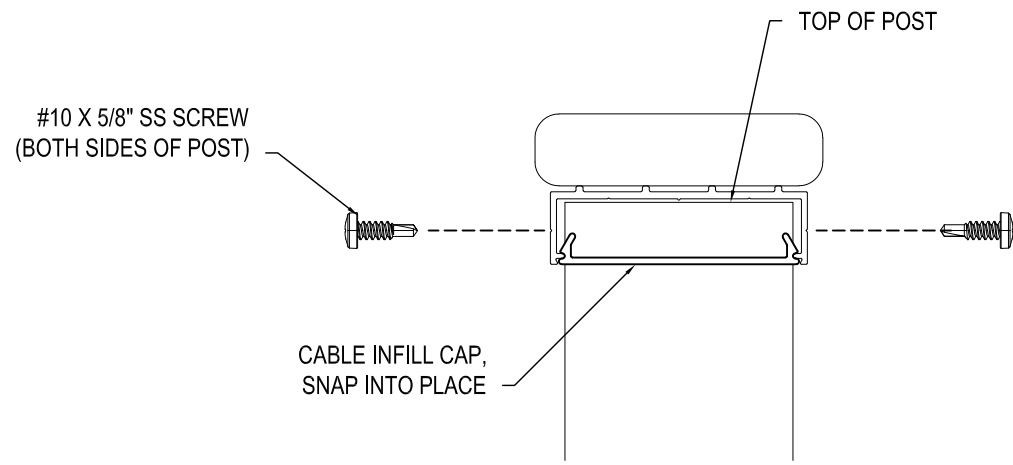
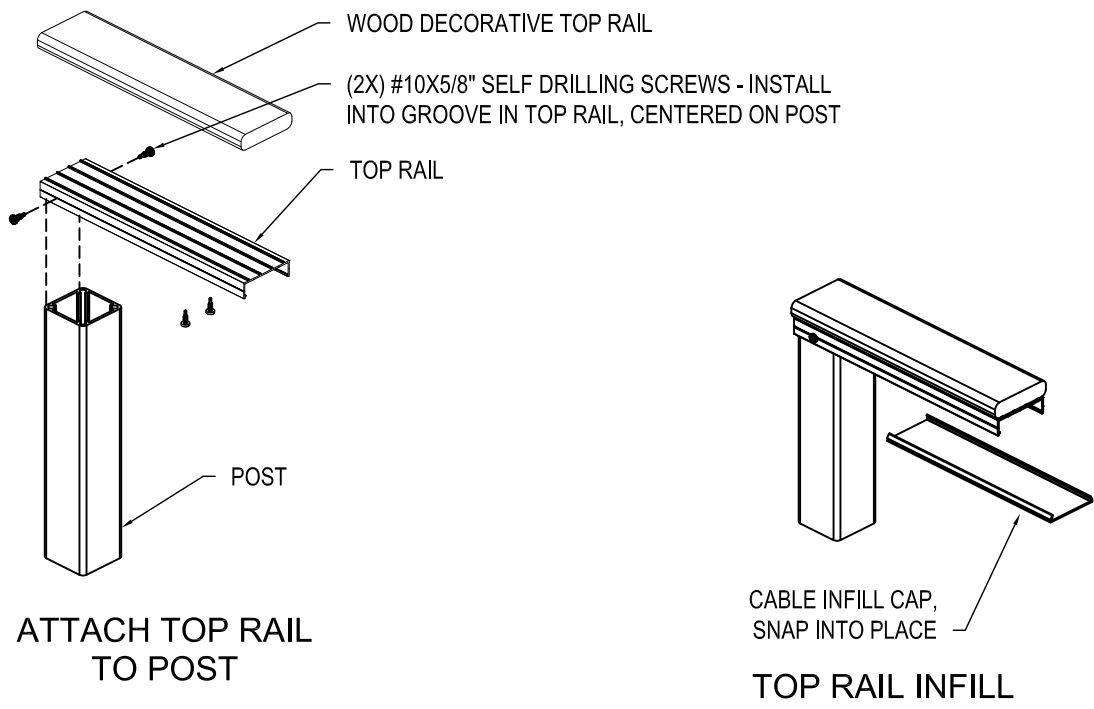

INSTALL BOTTOM RAIL BEFORE TOP RAIL

DRAWING TITLE:
STEP 4: TOP RAIL INSTALLATION

DATE: 4/16/2020
 DRAWN BY: TJC

PRECISION RAIL
www.precisionrail.com
 503.512.5353
 855.776.7245



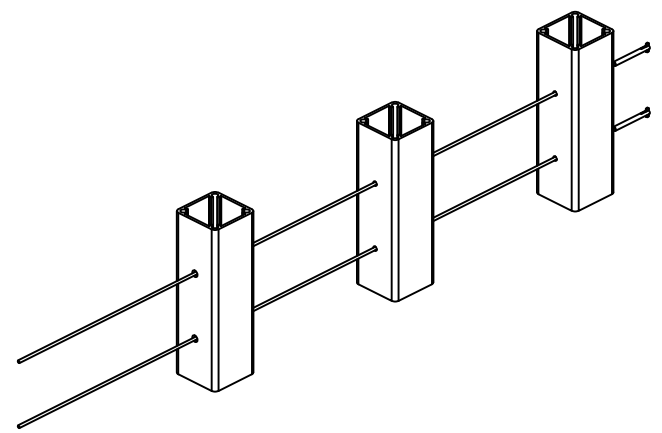
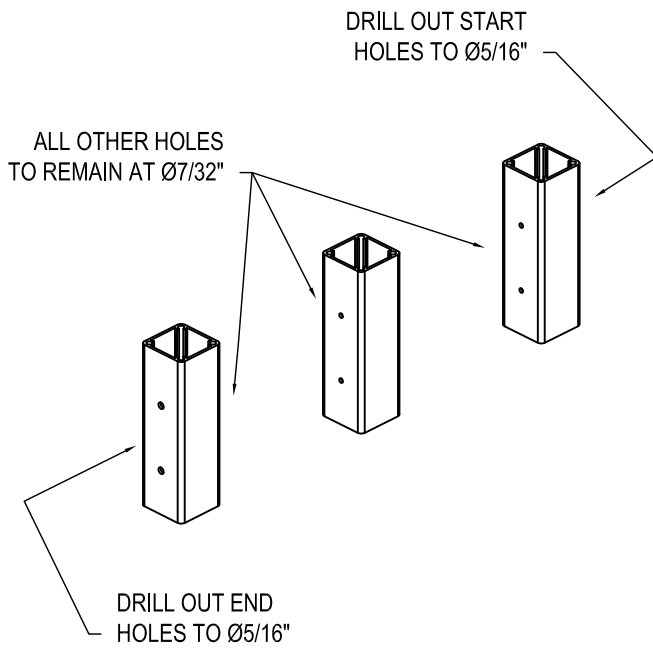

IT IS RECOMMENDED TO INSTALL CABLES LOOSELY PRIOR TO INSTALLING TOP RAIL, STARTING WITH THE BOTTOM CABLE AND WORK UP. THIS IS SO YOU CAN EASILY SEE THE CABLES INSIDE THE POSTS.

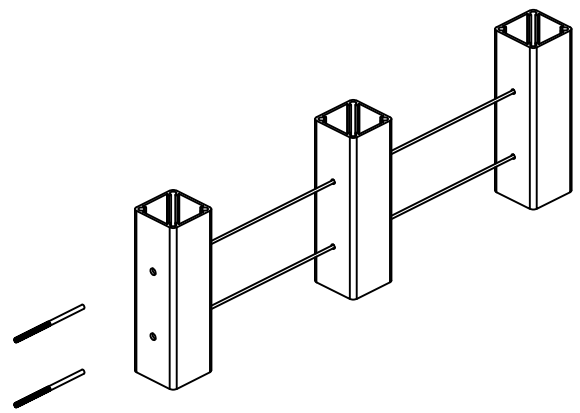

INSTALL THREADED TERMINALS.
(SEE NEXT PAGE FOR DETAILS)

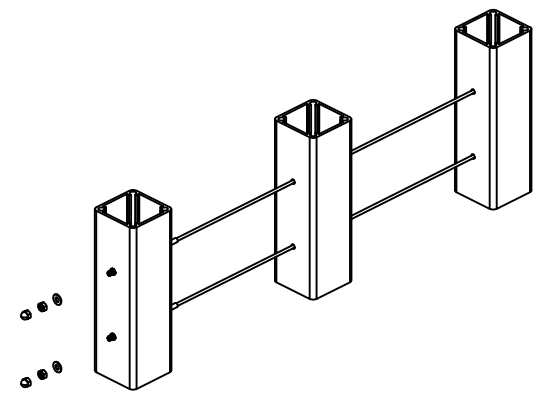

INSTALL WASHER, NUT, AND ACORN NUT.
TENSION CABLES AS REQ'D

DRAWING TITLE:
STEP 5: CABLE INFILL

DATE: 4/16/2020
DRAWN BY: TJC

PRECISION RAIL
www.precisionrail.com
503.512.5353
855.776.7245



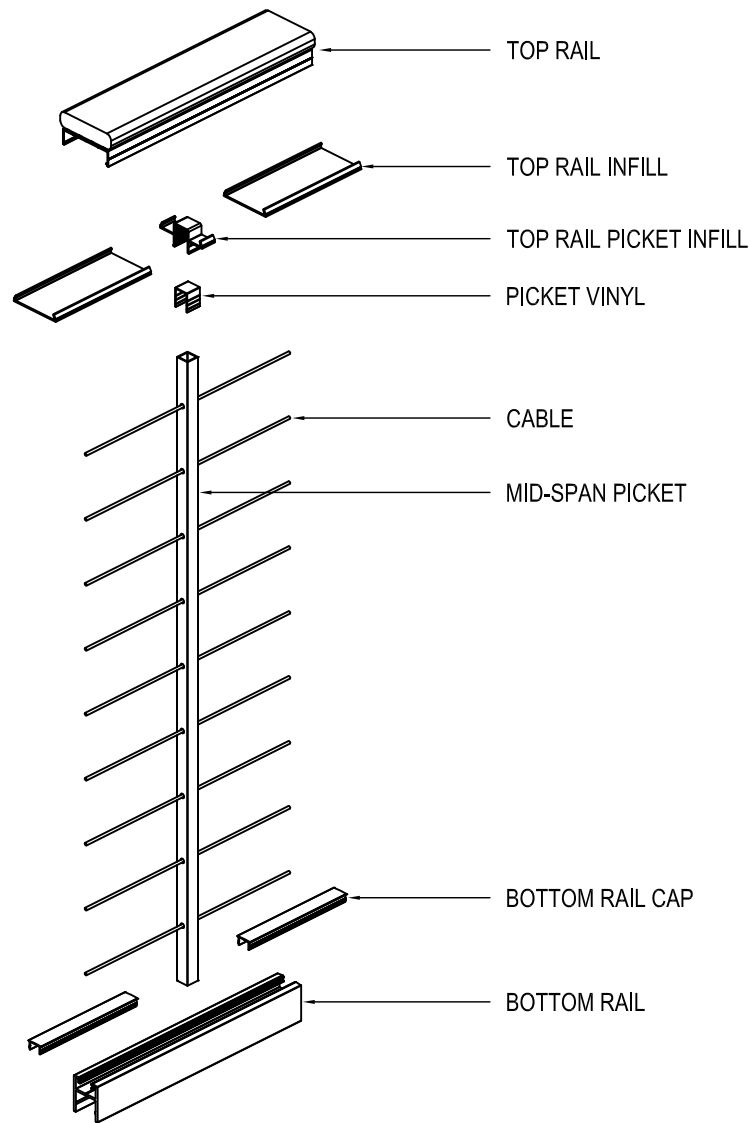

MID-SPAN PICKET DETAIL

DRAWING TITLE:

STEP 5: CABLE INFILL / PICKET

DATE: 4/16/2020

DRAWN BY: TJC

PRECISION RAIL
www.precisionrail.com
 503.512.5353
 855.776.7245



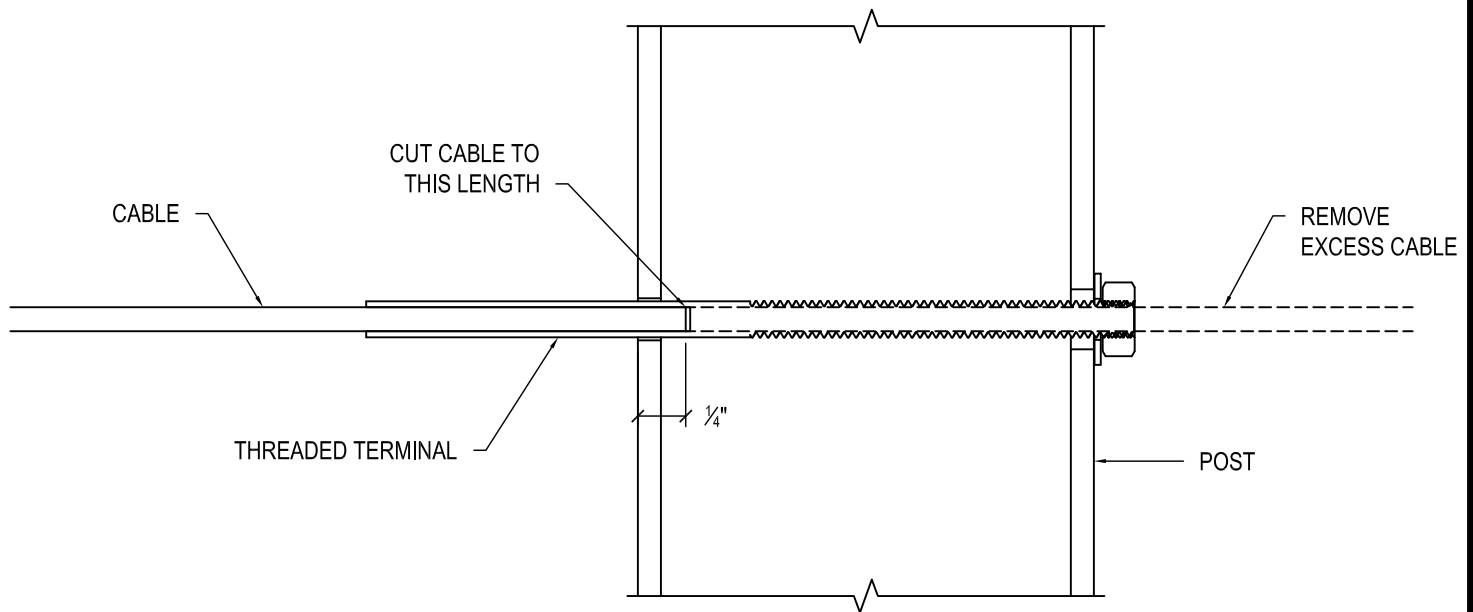

INSTALL THREADED TERMINAL ON CABLE AND USE SWAGE TOOL HERE TO PERMANENTLY ATTACH

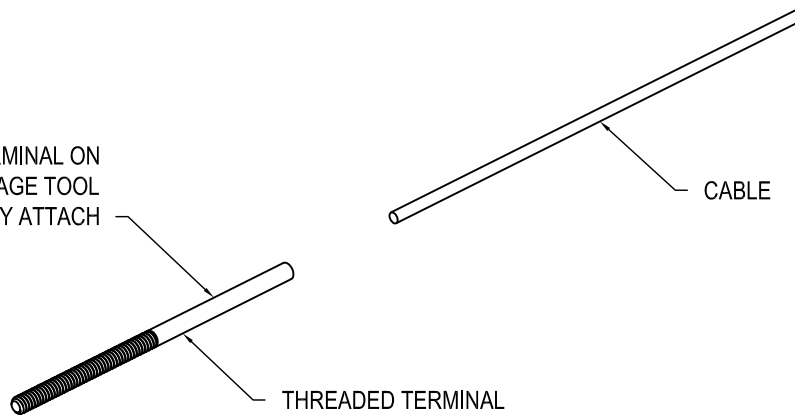

THINGS TO NOTE:

- IT IS ADVISED TO APPLY ANTI-SEIZE OR WD-40 TO THE THREADS ON THE THREADED TERMINAL PRIOR TO INSTALLING THE NUT AND WASHER.
- INSTALL NUT AND WASHER AS SHOWN AND PLACE THREADED TERMINAL INTO POST.
- DETERMINE THE DEPTH OF THE RECESSED END OF THE TERMINAL.
- CUT THE CABLE TO THE LENGTH DETERMINED, THEN REMOVE THREADED TERMINAL FROM POST.
- INSERT THREADED TERMINAL ONTO CABLE, USE THE SWAGE TOOL AS REQ'D TO ATTACH TERMINAL.
- SLIDE TERMINAL THROUGH HOLES IN POST AND LOOSELY INSTALL NUT AND WASHER.
- ONLY TIGHTEN CABLES AFTER ALL TOP AND BOTTOM RAILS HAVE BEEN INSTALLED.
- TIGHTEN THE CABLES ALTERNATING FROM TOP TO BOTTOM MOVING TOWARDS THE MIDDLE CABLE, SIMILAR TO TIGHTENING LUG NUTS ON A WHEEL INSTEAD OF GOING IN A CIRCLE.

DRAWING TITLE:

STEP 5: CABLE INFILL

DATE: 4/16/2020

DRAWN BY: TJC

PRECISION RAIL
www.precisionrail.com
 503.512.5353
 855.776.7245

